



GUARDIAN RCC-50

Reciprocating Compressor Controller

- **Single-stage or Dual-stage Reciprocating compressor controller**
- **Pressure, temperature, capacity% and load% displays**
- **Suction pressure setpoint control of up to 4 capacity loading valves**
- **Alarm and trip monitoring**
- **Multiple pack/compressor system control**
- **Local panel operation and set-up of pack configuration & control modes**
- **Communications for remote monitoring and set-up**

Operation and Setup Manual

The GUARDIAN RCC-50 Compressor Pack Controller provides suction pressure setpoint control and alarm monitoring for either a single-stage or a dual-stage large industrial reciprocating compressor with up to 4 loading valves.

Contents

GUARDIAN RCC-50	1
GETTING STARTED	4
BUTTON OPERATION SHORTHAND	5
HARDWARE CONFIGURATION CHECKS	5
CONFIGURE UNIT MODEL, SYSTEM No & ADDRESS	6
Enter Passcode	6
Select Unit Model	6
Select System No and Address	7
RS485 Communications	7
UNIT MODELS	8
OVERVIEW	8
Functions.....	8
Displays.....	9
Pushbuttons	9
GENERAL SPECIFICATION	10
AVAILABLE UNIT MODELS (RCC-50)	10
<i>RCC-50 Input/Output Signals</i>	11
RCC50 Fuse Ratings	12
RCC50 FUSES and LED LAYOUT	13
RCC-50 Termination Wiring - SSrL model selection	14
RCC-50 Termination Wiring - dSrL model selection	15
OPERATION	16
RCC-50 PANEL LAYOUT	16
CONTROL STATUS LED LAMPS	16
LED LAMPS	17
ALARM INPUTS.....	17
SYSTEM STATUS DISPLAYS.....	17
Enter System Setup Mode.....	17
Control status displays	18
Relay output status.....	18
Inputs.....	18
Trip inputs.....	19
SAFETY TRIP INDICATIONS.....	19
DISPLAY PUSHBUTTON OPERATION	20
‘view’	20
‘type’.....	20
CONTROL PUSHBUTTON OPERATION	22
“mode”	22
“Mode-MANUAL”	22
“Mode-AUTOMATIC”	22
“RESET”	23
“stop”	23
“start”.....	23
“Lower”	23
“Raise”	23
SETTINGS CHANGE PUSHBUTTON OPERATION	24
“next”	24
“Accept”	24
“raise”	24
“Lower”	24
ALARM ACCEPT AND RESET PUSHBUTTON OPERATION	25

SETPOINTS	26
CONTROL MODES	27
CONTROL.....	28
COMPRESSOR CONTROL OPERATION.....	28
POWER UP.....	28
RUNNING	28
STOPPING.....	30
MODES CHANGES	30
TIMER SETPOINTS	30
SETUP	31
Compressor Settings	31
Unit Settings:.....	31
Clock Settings	31
System Settings	32
Port Settings.....	33
Hours run	33
Analog.....	33
PT.....	33
Test	34
Done.....	34
TRANSDUCER SETUP & CALIBRATION	35
TRANSDUCER SETUP.....	35
PRESSURE TRANSDUCER SETUP	36
CAPACITY % SETUP	37
MOTOR LOAD % SETUP	37
COMMUNICATIONS.....	38
MONITOR HIGHWAY MODBUS COMMUNICATIONS (COM1)	38
CONTROL HIGHWAY COMMUNICATIONS (COM2)	39
Suction Group Control Communications.....	40
Setup / Commissioning Parameters	41
Settings display and change facilities.....	43
RCC-50 Enclosure wiring: for trips negative	45
RCC-50 Enclosure wiring: for trips positive.	46
FITTING NEW EPROM	47
CORRECT POSITIONING OF EPROM <u>ALIGN INDICATED INDENTS</u>	47
Index	48

GETTING STARTED

Guardian Controllers provide refrigeration engineers with

- **ULTIMATE FLEXIBILITY**
- **ASSURED MONITORING**
- **RELIABLE ALARMS**

This manual provides refrigeration designers, installers, service mechanics and supermarket personnel with the necessary information to achieve the above objectives.



All users require to know a few basic facts about this controller before successfully starting to perform their design, commissioning, maintenance or operating functions.

- All GUARDIAN controllers need to be set up with a unit model selection and other basic settings for setpoints, timers and addresses.
- The shorthand used in the following chapters for concisely expressing button pressing and selection sequences to do all this set-up needs to be understood.
- Mains power input voltage and hardware switch and link option selections (if any are required) must correspond to the selected unit model configuration.
- Since each controller can be configured in a number of different ways to perform flexible refrigeration control then an understanding of how to find out what unit model is currently selected, what it does and how it is connected, is also necessary.



BUTTON OPERATION SHORTHAND

To assist in easy set-up of control setpoints, delays, timers and other configuration settings, the sequence of button presses and subsequent displays will be shown in this handbook as below:

- ii) A button symbol, followed by text means press that button. “ accept”
- iii) A double button, followed by text means press that button repeatedly. “ raise”
- iv) A display box with the window above it shows the result of the last button press on the display.



- v)

DISCHARGE	OIL2	DISCHARGE	OIL2
			

Means the display alternately flashes between identifier and trip message

HARDWARE CONFIGURATION CHECKS

Prior to switching on the GUARDIAN controller check that the hardware unit is the correct type for the incoming mains voltage.

When satisfied that the correct type of controller is available then the following checks should be made prior to controller installation or replacement

- a) Ensure mains supply is wired correctly to the appropriate TERMINAL WIRING drawing for the model selected.
- b) Ensure that any transducer selector switches specified on the TERMINAL WIRING diagram are in the correct state.
- c) Ensure any shorting link selector pins specified on the TERMINAL WIRING diagram are correctly fitted.
- d) Ensure that probes are wired to the terminal WIRING DIAGRAM and the correct type of thermistor or pressure transducer probes are fitted.
- e) The RS485 highway connections (if required) are wired to the correct terminals and the screen drain wire is continuous to earth.

CONFIGURE UNIT MODEL, SYSTEM No & ADDRESS

Enter Passcode

Before any permanent change of controller settings are made then the correct entry of the appropriate passcode is necessary.

The settings available for change on each passcode are as follows;

		Passcode
Passcode level 1	setpoints, low & high alarm settings	07
Passcode level 2	low & high trip settings and all level 1	09
Passcode level 3	system settings and levels 1 & 2	15

Enter passcode 15

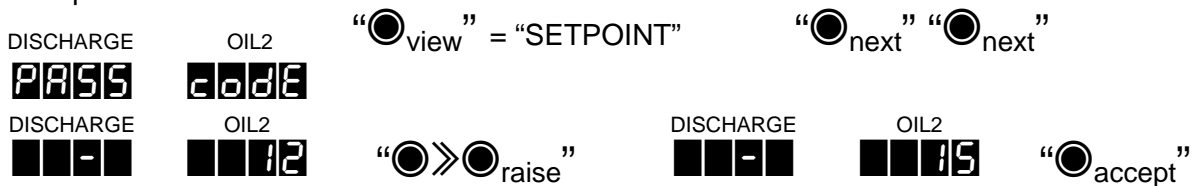

Press "view" to select "SETPOINT", then press the "next" button twice to enter the passcode settings.

Press "raise" repeatedly until passcode **15** is selected and then press "accept"

Select Unit Model

Enter Passcode as button sequence above.

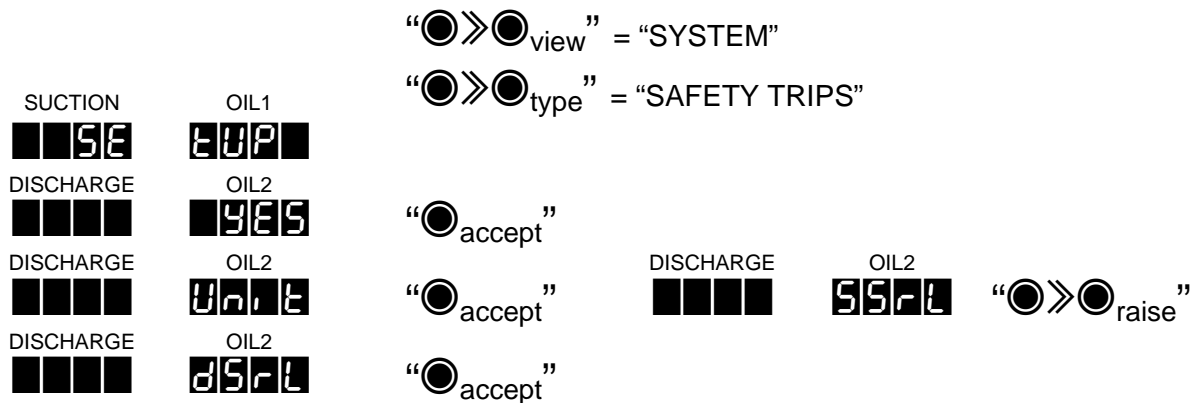

Press 'view' repeatedly until 'SYSTEM' is selected.

Press 'type' repeatedly until 'SAFETY TRIPS' is selected. Press 'accept'

'Unit' is displayed press 'accept'

Display shows unit model currently selected which may be wrong.

Press 'raise' repeatedly until correct model is displayed (e.g.SSrL) and then press 'accept' which causes the display to wink briefly and display the new unit model selection (e.g dSrL)

Select System No and Address

e.g. setup unit for system 65 compressor number 1 at address 195

Enter setup as button sequence as above

SUCTION	OIL1		
■■■SE	EUP■■		
DISCHARGE	OIL2		
■■■■	YES■■	“○accept”	
DISCHARGE	OIL2		
■■■■	Unit	“○accept”	
DISCHARGE	OIL2		
■■■■	Sno1	“○>>○raise”	
DISCHARGE	OIL2		
■■■■	Eno1	“○next”	
DISCHARGE	OIL2		
■■■■	Eno1	“○accept”	
DISCHARGE	OIL2		
■■■■	A01	“○next”	
DISCHARGE	OIL2		
■■■■	A195	“○>>○raise”	
DISCHARGE	OIL2		
■■■■	A195	“○accept”	“○>>○next”
DISCHARGE	OIL2		
■■■■	done	“○accept”	

RS485 Communications

When the correct system number, case/compressor number and highway address have been entered as above then the controller can communicate with the GUARDIAN Consultant Terminal PC for central alarm monitoring and temperature display. Control setpoints, timers and alarm limits may then be sent to the controller from the PC.

For further details see page 38

UNIT MODELS

Guardian controllers may be configured in a number of different ways dependent on unit model selection. Each unit model fulfils a different refrigeration temperature monitoring and control requirement. In order to perform the required refrigeration control then each model has different uses for the controller's input output signals. This section gives details of all the model variations available for the controller and the way to connect the wiring to the plant devices and measuring transducers.

OVERVIEW

Functions

The GUARDIAN RCC-50 controller provides facilities for:-

MONITORING

Measurement of 5 pressures and 5 temperatures and pack load for control, alarm and trip display.

Calculation of differential pressures and superheat temperatures for control, alarm and trip display.

Detection of digital input states on up to 8 safety trip inputs.

ALARMS

Detection after a preset guardtime of pressure and temperature High/Low alarms when the compressor is in operation. Alarms are indicated by alternating a **Hi** or **Lo** message on the appropriate temperature or pressure display.

TRIPS

Detection of pressure and temperature High/Low trips which stop the compressor. Trips are indicated by the flashing red TRIPPED lamp and an alternating 'TRIP' message on the appropriate temperature/pressure display.

Automatic trips include:-

- high discharge temperature
- low suction pressure
- high discharge pressure
- MCB overload
- high/low suction superheat
- low oil flow
- Low oil level

Detection of safety trips which stop the compressor.

Trips are indicated by the flashing red TRIPPED lamp and an appropriate message.

Trips vary dependent on pack model configuration.

ie :- **hndb**, **H.P.**, **d.P.P.**, **SSSE** alternating with a **TRIP** message on the appropriate display.

CONTROLS

Control of compressor motors, and different combinations of loading valves dependent on suction pressure setpoint.





Startup and run sequences use preset timers and limits plus compressor runhours to determine control sequence actions.

Compressor stage is indicated by LED lamps on the control panel.

Suction pressure initiation of other compressors in the system via a RS485 link when in REMOTE mode.

Displays

i). SUCTION, DISCHARGE, OIL1 & OIL 2 .

SUCTION 	OIL1 	4-digit 7-segment LED displays for display of measurements setpoints/limits for temperatures and pressures The contents change dependent on 'view' and 'type' selections
DISCHARGE 	OIL2 	

ii). CAPACITY%.

CAPACITY% 	3-digit 7-segment LED displays for display of loading timers and capacity.
--	--

iii). MOTOR LOADING%.

MOTOR LOAD% 	3-digit 7-segment LED displays for display of timers and motor load.
--	--

iv). COMPRESSOR No.

No 	1-digit 7-segment LED display
--	-------------------------------

Pushbuttons.

All pushbuttons are embossed, tactile membrane switches.

start, stop, raise & lower	used to control compressors when in manual mode.
RESET	used after a trip to reset the compressor.
Mode, view & type	used in conjunction with appropriate LED displays to select control, display or settings change facilities.
accept, next	used in conjunction with raise, lower and appropriate LED displays during setpoint and limit settings changes.

Unaccepted alarms and trips are acknowledged by pressing accept.

Pushbuttons on the local control panel permit operator display of setpoints, pressures, temperatures, alarm and trip settings and compressor runhours and status. Setpoints, alarm and trip settings may be changed from the panel after entry of the appropriate passcode.

The compressor may be selected to operate in one of three control modes:-

MANUAL, LOCAL or REMOTE MODES.

Safety interlocks, alarm, trip, startup and shutdown sequence controls are automatic in all three modes.

In **MANUAL** mode, the each compressor may be individually started and stopped and the pack capacity raised and lowered by operator pushbutton control from the local panel.

In **LOCAL** automatic mode, the compressor is started and stopped under control of the suction pressure setpoint.

REMOTE automatic mode allows up to six RCC-50 units to be connected via a two-wire communication link (RS485) to provide 6-unit system control.

GENERAL SPECIFICATION

Power	110 or 230 Vac 50 hz 30VA (dependent on model type)
Operation	0 to 50°C
Approx. Dimensions:	
Control panel:	300 x 220mm
Control unit:	300 x 230 x 90mm

The GUARDIAN RCC-50 control unit comprises a printed circuit board in an IP65 ABS enclosure for mounting at the rear of the compressor pack control panel with the display unit mounted on the door and has overall dimensions:- 300 x 230 x 90mm.

The unit is fitted with two-part screw-clamp terminals for the connection of the appropriate input/output signals. (See input/output section)

The GUARDIAN RCC-50 control panel comprises a membrane, pushbutton and display panel mounted on the front of the control unit.

The membrane front panel has a Black background with white lettering and blue buttons with dimensions 300x220mm.

AVAILABLE UNIT MODELS (RCC-50)

C1LF	1 compressors with 4x25% loading selection 4 condenser fans 8 trips 2 alarms	Low Liquid Level Condenser Fan Fail
	1 input	External Max demand unload i/p
C1L4	1 two-stage compressor with 0,30,60,80,100% loading selection with intermediate pressure 4 condenser fans 8 trips 3 start signals 2 alarms	Low Liquid Level Condenser Fan Fail
	1 input	External Max demand unload i/p

RCC-50 Input/Output Signals

C1L4			
Analogue inputs			
A1	Suction pressure	4 to 20mA	-1 to 24 bar g
A2	Discharge pressure	4 to 20mA	-1 to 24 bar g
A3	C1 oil pressure	4 to 20mA	-1 to 24 bar g
A4	Intermediate pressure (dSrL only)	4 to 20mA	-1 to 24 bar g
A5	Suction temperature	PT1000	-50 to 180°C
A6	Discharge temperature	PT1000	-50 to 180°C
A7	Oil temperature	PT1000	-50 to 180°C
A8	Intermediate temperature (dSrL only)	PT1000	-50 to 180°C
A9	(Optional liquid level)	0 to 5V dc	0 to 100%
A10	(Optional pack load %)	0 to 10V dc	0 to 127%
A11	Not used		
Calculated inputs			
	Total pack capacity		
	Equivalent Suction temperature		
	Equivalent Discharge temperature		
	Equivalent intermediate temperature		
	Diff discharge pressure		
	Diff oil pressure		
	Diff pump pressure		
	Hours run		
Digital inputs			
Trip 1	High discharge temperature trip		
Trip 2	L.P Safety trip		
Trip 3	H.P safety trip		
Trip 4	Oil Level trip (surge drum high)		
Trip 5	Oil flow trip		
Trip 6	M.C.B overload trip		
Trip 7	Emergency stop		
Trip 8	System trip (intercooler high)		
12/24V dc inputs			
Input A	Max demand reduce load		
Input B	Keyswitch		
Input C	Condenser fan fail		
Input D	Liquid Level Alarm		
Mains inputs			
Input E	Liquid pump running		
Input F	Condenser fans running		
Input G	External start/stop		
Input H	Not used		
input I	External reset pushbutton		
Relay outputs			
R1	Motor 1 contactor		
R2	Loading 30%		
R3	Loading 60%		
R4	Loading 80%		
R5	Loading 100%		
R6	Not used		
R7	Not used		
R8	Not used		
R9	Not used		
Extension outputs			
OP1	Not used		
OP2	Not used		
OP3	Not used		

RCC50 Fuse Ratings

FUSE	Rating	Littlefuse part	CCT protection	Terminal s
F101	125 mA	0453 .125	Com 2 RS485 B line	TB11-2
F102	125 mA	0453 .125	Com 2 RS485 A line	TB11-3
F103	125 mA	0453 .125	Com 1 RS485 B line	TB4-2
F104	125 mA	0453 .125	Com 1 RS485 A line	TB4-3
F105	1 A - T	0454 001.	Display	CN1
F106	1 A - T	0454 001.	Extension	CN2
F201	1 A - T	0454 001.	24 Vdc supply	TB12A-1
F202	1 A - T	0454 001.	12 Vdc supply	TB12-4
F203	125 mA	0453 .125	24 Vdc supply	TB5-2
F204	3.5 A - T	0454 03.5	24 Vac Incoming	TB3-1
F401	125 mA	0453 .125	24 Vdc supply	TB10A-4 TB10-4 TB6-16 TB6-12 TB6-8 TB6-4 TB7A-5
F402	125 mA	0453 .125	5 Vdc supply	TB7-5

RCC-50 Termination Wiring - SSrL model selection

Single-stage Compressor with Three Stages of Loading Control

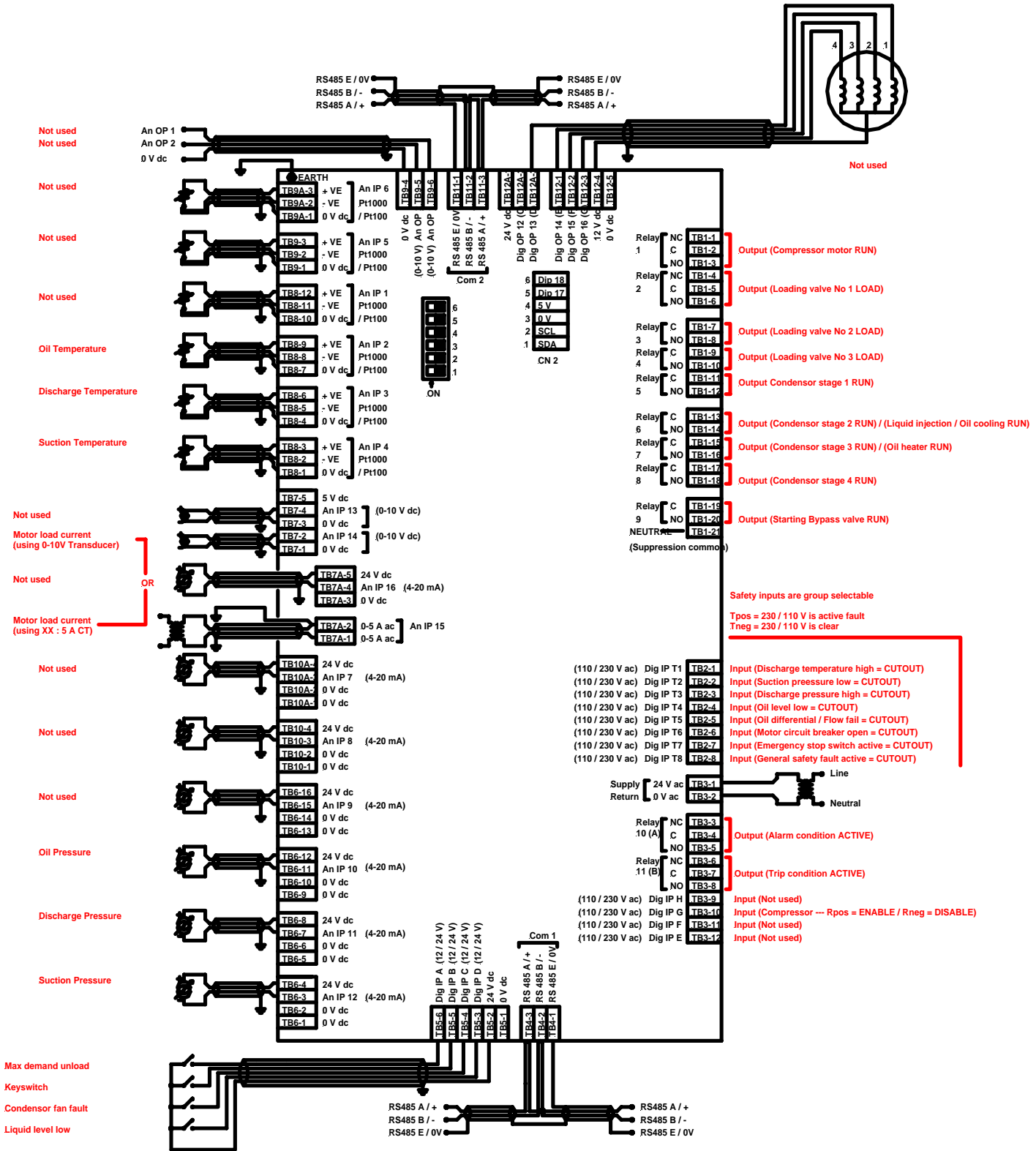

RCC-50 Termination Wiring - dSrL model selection

Dual-stage Compressor with Four Stages of Loading Control

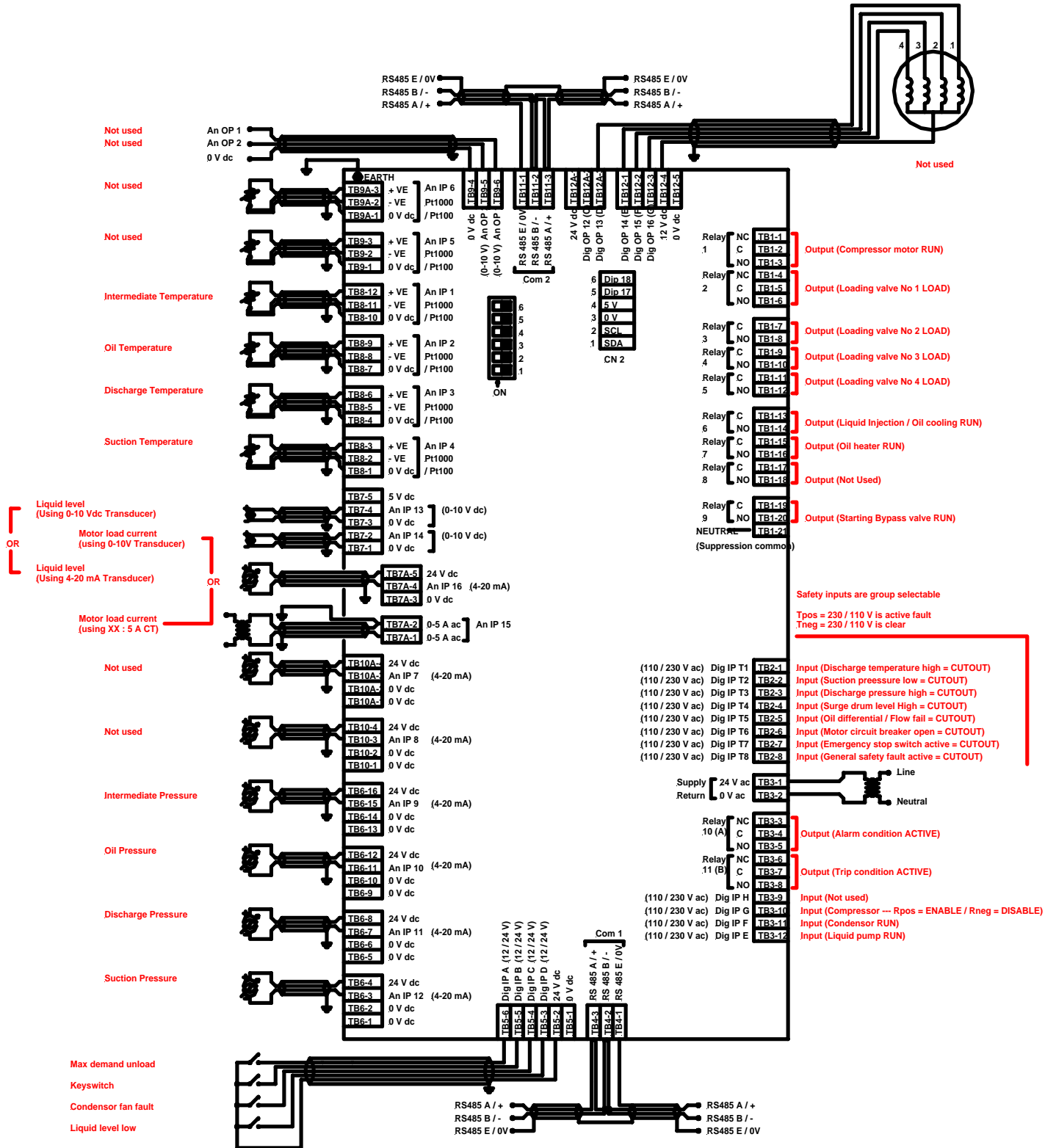

OPERATION

RCC-50 PANEL LAYOUT

GUARDIAN RCC-50 control panel comprises a membrane pushbutton and display panel mounted on the front of the control unit.

The membrane front panel (shown below) has a black background with white lettering and green buttons with dimensions 300 x 200mm and houses:-

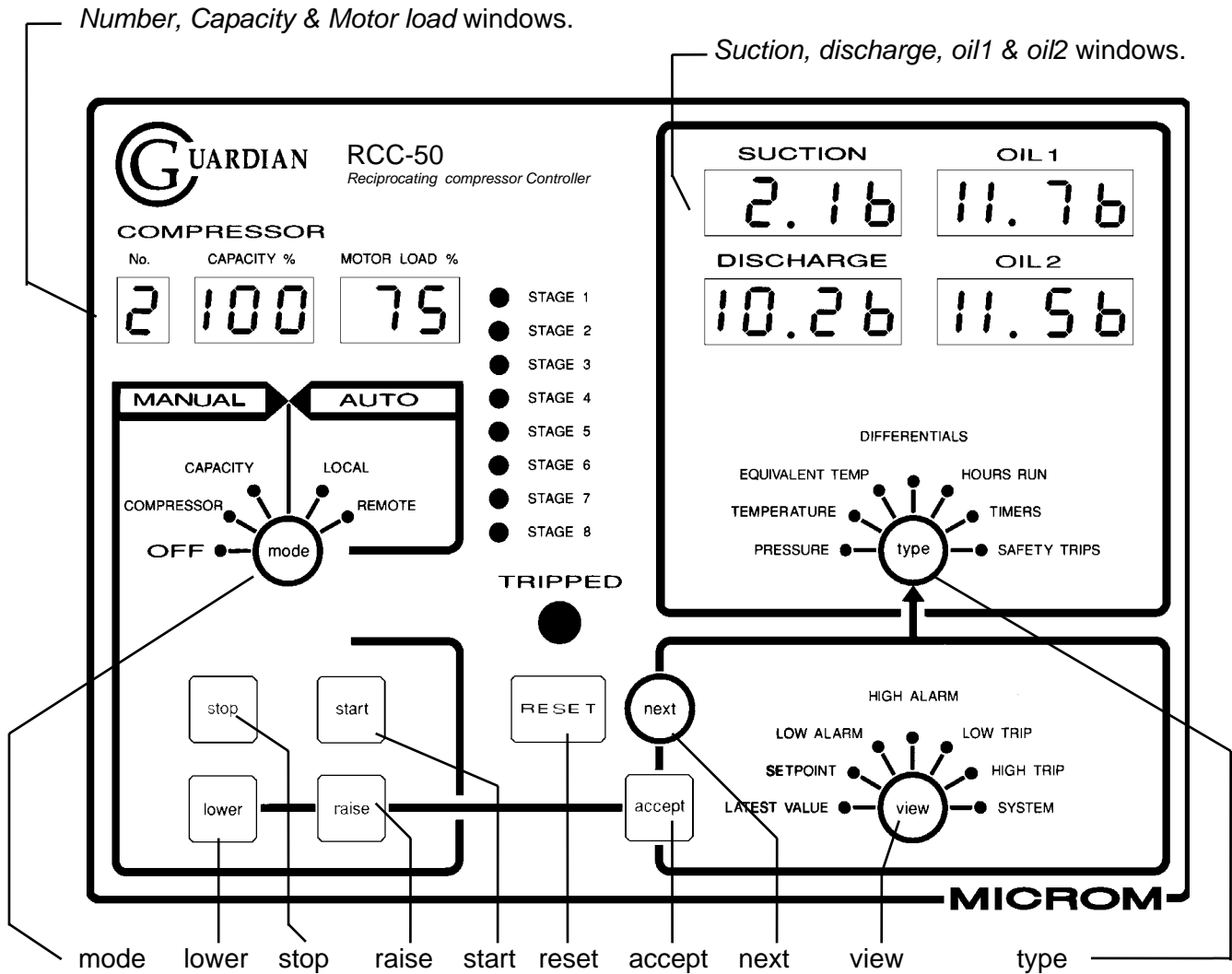

CONTROL STATUS LED LAMPS

STAGE 1 to Stage 8 Status LED lamps indicate the current pack stage of loading.

LED LAMPS.

Stage 1 to 8	Used to display compressor control stage status
TRIPPED	Flashing RED compressor tripped indicator
MANUAL	Mode selections: OFF, COMPRESSOR, CAPACITY
AUTOMATIC	Mode selections: LOCAL, REMOTE
'type'	7 led lamps. Selection for 4-digit LED displays PRESSURE, TEMPERATURE, EQUIVALENT TEMPERATURE DIFFERENTIALS, HOURS RUN, TIMERS & SAFETY TRIPS
'view'	7 led lamps. Selection for 4-digit LED displays LATEST VALUE, SETPOINT, LOW ALARM, HIGH ALARM, LOW TRIP, HIGH TRIP & SYSTEM

ALARM INPUTS

When detected, the following digital alarm inputs alternate the alarm messages below with 'TRIP' in the windows specified and flash the 'type' = TIMERS LED lamp.

Fans overload	FAnS	TriP	SUCTION
Liquid level alarm	LEvL	TriP	DISCHARGE

Accept and reset procedures are the same as for other trips.

SYSTEM STATUS DISPLAYS

System status and set-up data may be displayed by selecting the following;

Press “type” until “SAFETY TRIPS” is selected.

Press “view” until “SYSTEM” is selected.

The data is displayed in the in the *SUCTION*, *DISCHARGE*, *OIL1* and *OIL2* windows by pressing “next.” Only displayed if keyswitch ON, or passcode = 3

Enter System Setup Mode

SUCTION	OIL1
	

DISCHARGE	OIL2
	

Press “accept” to enter system set-up mode

Terminate passcode operation.

SUCTION	OIL1
	

DISCHARGE	OIL2
	













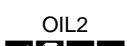

Press “accept” to remove passcode

Control status displays.

SUCTION OIL1
 

DISCHARGE OIL2
 

YYYY=

DISCHARGE	OIL2	
		Remote master suction control.
DISCHARGE	OIL2	
		Remote but at maximum load.
DISCHARGE	OIL2	
		Remote slave in load sharing.
DISCHARGE	OIL2	
		Remote mode, stopped but ready.
DISCHARGE	OIL2	
		Compressor in local mode
DISCHARGE	OIL2	
		Local mode but inhibited.
DISCHARGE	OIL2	
		Compressor in manual.
DISCHARGE	OIL2	
		Compressor OFF.

Relay output status.

SUCTION OIL1
 

DISCHARGE OIL2
 

 Is displayed if relay is OFF





 to  Is displayed if relay is ON.

Relay output is dependent on model configuration.

Inputs

SUCTION OIL1
 

DISCHARGE OIL2
 

	Max demand unload input
	Optional keyswitch input
	Low liquid level alarm.
	Condenser fan fail
	Not fitted.

Trip inputs.

SUCTION OIL1
 

DISCHARGE OIL2
 

 Is displayed if trip input is OFF

 Is displayed if trip input is ON.

Trip input message depends on model configuration.









Trip inputs can be selected (**tPoS** or **tneg**) to act if active trip signal is positive or negative. .

SAFETY TRIP INDICATIONS

When detected, the following safety trips alternate the trip messages below with **'TRIP'** in the windows specified and flash the **'type'** = SAFETY TRIPS LED lamp.

Accept and reset procedures are the same as for other trips.

The messages depend on the model configuration

Trip	Model RCC-50	message	flash	window
T1	Discharge temp hi trip		Trip	OIL2
T2	L.P. cutout		Trip	SUCTION
T3	H.P. cutout		Trip	DISCHARGE
T4	oil flow switch		Trip	OIL2
T5	oil level		Trip	OIL1
T6	motor circuit breaker		Trip	SUCTION
T7	emergency stop		Trip	DISCHARGE
T8	safety trip (other)		Trip	OIL

DISPLAY PUSHBUTTON OPERATION

Display of all compressor measured values, setpoints, alarm and trip limit settings is performed by repeated pressing of either the **'view'** and / or **'type'** pushbuttons.

At each button press the associated selection LED lamp advances by one in a clockwise direction indicating the type or setting of the value displayed in the;

SUCTION, DISCHARGE, OIL1, OIL 2, CAPACITY% and LOAD% windows.



'view'



To display the latest temperature values, the **'view'** pushbutton is pressed repeatedly until the **LATEST VALUE** LED lamp is lit.

'type'

The **'type'** pushbutton is then pressed repeatedly until the **TEMPERATURE** LED lamp is lit.

The **SUCTION, DISCHARGE, and OIL** windows now display the latest measured values of suction, discharge and oil temperatures respectively.



“ >>  view” = “LATEST VALUE”

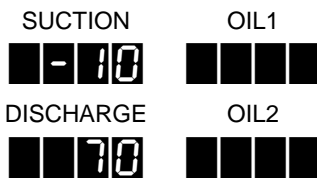

“ >>  type” = “TEMPERATURE”



To display the high alarm settings for pressures, the **'view'** pushbutton is pressed repeatedly until the **HIGH ALARM** LED lamp is lit, and then the **'type'** pushbutton is pressed repeatedly until the **PRESSURE LED** lamp is lit.

The **SUCTION, DISCHARGE, OIL and OIL 2** windows now display the high alarm limit settings, if applicable, for suction, discharge, oil and oil 2 pressures respectively.

“ >>  view” = “HIGH ALARM”

“ >>  type” = “PRESSURE”

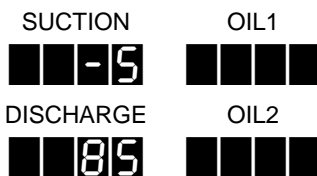

All pressures are displayed in the range: -1.0b to 24.0b where b= bar gauge



All temperatures are displayed in the range -50C to 125C where C= degrees centigrade



LOAD% and CAPACITY% are 0% to 125% where % is of maximum scale.
displayed in the range

Compressor **HOURS RUN** is displayed using the SUCTION and OIL windows from 0 to 65000 in the form

SUCTION	OIL1
■■■65	000H
DISCHARGE	OIL2
■■■■	■■■■

TIMERS setpoints for stage-up and stage-down, oil diff are displayed in minutes

“  view” = “SETPOINT”

“  type” = “TIMERS”

SUCTION	OIL1
3.2u	2.5P
DISCHARGE	OIL2
2.3d	1.5o

u = stage-up = 3.2 mins

P = C1 oil diff = 2.5 mins

d = stage-down = 2.3 mins

o = C2 oil diff = 1.5 mins

If no buttons have been pressed for 5 minutes, the SUCTION, DISCHARGE, OIL1 and OIL2 windows revert to the default display of latest pressure values with;

'view' = LATEST VALUE,

'type' = PRESSURE

CONTROL PUSHBUTTON OPERATION

“mode”

mode may be pressed at any time to change the operating mode of the compressor from '**MANUAL**' to '**AUTOMATIC**' control and visa versa. At each button press the associated 'mode' selection LED lamp advances by one in a clockwise direction indicating the required new mode selection.

Note: Compressor Mode changes only take place when the mode selection has been unchanged for 5 seconds.

“Mode-MANUAL”

With the '**OFF**' LED lamp selected in **MANUAL** mode, all compressors are automatically stopped if any stage 1-8 LED lamp is lit and subsequently ignores any further manual or automatic control requests.

With the '**COMPRESSOR**' LED selected in **MANUAL** mode, a particular compressor may be started and stopped by operator pushbutton control using '**start**' and '**stop**' after using 'next' to select the required compressor number.

With the '**CAPACITY**' LED selected in **MANUAL** mode, the selected compressor capacity may be changed by operator pushbutton control using 'raise' and 'lower' buttons, provided the compressor is running.

“Mode-AUTOMATIC”

In **LOCAL** automatic mode, the compressor is started and stopped under control of the suction pressure setpoint. Operation in this mode is independent of any other compressors in the system.

REMOTE automatic mode allows up to four SCC-50/RCC-50 units to be connected via a two-wire communication link to provide 6-compressor system control. Any change to REMOTE mode whilst the compressor is running causes the compressor to automatically load up to 100% or assume suction pressure control if it is the only one in remote mode.

“RESET”

RESET is used to reset all control sequences prior to restarting the compressor after a **'TRIPPED'** condition has occurred and subsequently been corrected. When pressed with the **'TRIPPED'** LED lamp either flashing or steady the TRIPPED lamp is switched off, any flashing **'type'** alarm selection LED lamp goes steady, all display measurement values are unfrozen from the pre-trip conditions and revert to latest values .

“stop”

stop may be pressed at any time in either **'MANUAL'** or **'AUTOMATIC'** mode and, if the selected compressor is running, causes the compressor to shutdown and stop in an orderly manner.

The stop sequence unloads valves, stops the compressor, extinguishes the **'STAGE 1-8'** LED lamps, starts the **delay after stop** timer,

“start”

start only operates in **'MANUAL'** mode with the **'COMPRESSOR'** LED lamp selected. The selected compressor is started and the appropriate STAGE1-8 LED lamp illuminated, resets the **time between starts** timer.

“Lower”

lower may be used in **'MANUAL'** mode with the **'CAPACITY'** LED lamp selected. Whilst 'lower' is being pressed, the slide unloading solenoid valves are changed and the **'STAGE 1-8'** LED lamps are extinguished.

The 'lower' pushbutton is also used after 'next' has been pressed to decrease the displayed values of setpoints, high, low, alarm and trip settings prior to changing them using 'accept'.

“Raise”

raise may be used in **'MANUAL'** mode with the **'CAPACITY'** LED lamp selected and the **'TRIPPED'** LED lamp off. Whilst **'raise'** is being pressed, the slide loading solenoid valves are increased and the 'STAGE 1-8' LED lamps are lit.

The **'raise'** pushbutton is also used after 'next' has been pressed to increase the displayed values of setpoints, high, low, alarm and trip settings prior to changing them using **'accept'**.

SETTINGS CHANGE PUSHBUTTON OPERATION

“next”

'next' is used to initiate **'settings change'** operation provided an external security key or ink is activated or the appropriate passcode has been entered.

(See configure unit model section)

Passcode entries remain valid for 30 minutes.

Subsequent pressing of the **'next'** pushbutton cycles through the seven display windows flashing the last digit of each in turn to indicate which window is selected for changes. Unused windows are skipped.

Different settings may be displayed using **'view'** and **'type'** selections.

Changes are made by using the **'raise'** and **'lower'** pushbuttons to alter the displayed setting which then must be followed by pressing the 'accept' pushbutton.

“Accept”

'accept' pushbutton enters new values of setpoints, timers, alarm or trip settings.

“raise”

If the 'raise' pushbutton is held on for more than 2 seconds then the value increases automatically at a higher rate.

“Lower”

If the 'lower' pushbutton is held on for more than 2 seconds then the value decreases automatically at a higher rate.

If an attempt is made to change a setting using the incorrect passcode then the display defaults to:-

'view' = LATEST VALUE

'type' = PRESSURE

ALARM ACCEPT AND RESET PUSHBUTTON OPERATION

The “**accept**” pushbutton is used to acknowledge a high, low, alarm or trip condition. It stops the flashing of the '**type**' LED selection and the '**TRIPPED**' LED lamp thus allowing other '**view**' or '**type**' selections to be made in order to investigate the fault.

The '**TRIPPED**' LED lamp remains on until '**RESET**' is pressed. After an alarm, '**view**' and '**type**' selections are inhibited until 'accept' is pressed.

ALARM and TRIP INDICATIONS

The high and low alarm and trip conditions listed below are detected and displayed in all control modes.

New alarms or trips automatically select '**view**' = LATEST VALUE and flash the appropriate '**type**' LED lamp for the alarm or trip point ie (PRESSURE, TEMPERATURE, DIFFERENTIAL)

The window displaying the alarm point alternates the latest value with a '**trip**' , '**Hi**' or '**Lo**' fail message.

The **TRIPPED** LED flashes for all trips and the latest values are frozen at the time of the trip for subsequent fault diagnosis.

When '**accept**' is pressed the '**type**' LED stops flashing and other display selections may be viewed if required.

The alarm value continues to alternate with '**Hi**' or '**Lo**' whilst an alarm is present.

The tripped value continues to alternate with '**trip**' until 'RESET' is pressed.

Value	Description	Window	'type'	'view' selection			
				Lo-alarm	hi-alarm	low trip	high trip
1	suction press	SUCTION	PRESS	stop		yes	
2	discharge press	DISCHARGE	PRESS		start-unload		yes
3	oil pressure	OIL	PRESS				
4	Intermediate press	OIL2	PRESS				
5	suction temp	SUCTION	TEMP		yes		yes
6	discharge temp	DISCHARGE	TEMP		yes		yes
9	slide %	CAPACITY	PRESS	yes	stop-load		
10	motor load %	LOAD%	PRESS		start-unload		
Calc							
17	equiv-suct-temp	SUCTION	superheat				
18	equiv-disc-temp	DISCHARGE	superheat				
19	equiv-interm.-temp	OIL1	superheat				
21	suct-superheat	SUCTION	DIFF	yes	yes	yes	yes
22	diff-disc-pressure	DISCHARGE	DIFF				
23	diff-oil-pressure	OIL	DIFF	yes		yes	

SETPOINTS

SUCTION PRESSURE SETPOINT CONTROL.

the suction pressure control setpoint for the compressor in increments of 0.1 bar. Capacity loading takes place when the suction pressure is greater than the setpoint.

Capacity unloading takes place when the suction pressure is less than the deadband below the setpoint.

When the suction pressure is 0.5 bar above or below the setpoint then the loading delay timer is automatically halved to achieve suction setpoint more rapidly.

STOP-LOAD.

The % load current above which no further loading pulses are allowed. Loading pulses are also inhibited when the HIGH capacity limit is reached.

START-UNLOAD.

The % load current or the discharge pressure High Alarm Limits above which capacity unloading pulses are automatically started.

DISCHARGE TEMPERATURE HIGH ALARM= MOTOR-START-INHIBIT.

The discharge temperature above which the compressor is not allowed to start.

SUCTION PRESSURE LOW ALARM. = STOP COMPRESSOR

the minimum suction pressure for the compressor in increments of 0.1 bar. This setpoint merely stops the compressor which automatically restarts again when the suction pressure rises again without needing RESET to be pressed.

INTERMEDIATE PRESSURE.

On RCC50 units the intermediate pressure and saturated temperature are displayed under OIL2 and OIL1 windows after selecting type = Equivalent Temp.

CONTROL MODES

GENERAL

The controller is a general purpose compressor pack controller. It may be used as a stand-alone unit or may be integrated into an overall pack control strategy via the communications link with up to 6 other units.

The control and monitoring operations are based on the inputs and outputs described previously.

The controller has three modes of operation:-

i) MANUAL

Operator required to start/stop and control capacity

- Provided COMPRESSOR is selected the controller will respond to START being pressed.

ii) LOCAL AUTOMATIC

Compressor start/stops and controls capacity on suction pressure setpoint control

iii) REMOTE AUTOMATIC

Uses communications link to establish the most efficient loading of up to four compressors.

In a pack system of up to six compressors the compressor with the least runtime hours and which is also in the ready state is considered to be the Master. Once the suction pressure goes above the control setpoint then the Master compressor will start.

All modes support alarm and cut-out trip monitoring and automatic over-current and high discharge pressure capacity unloading.

CONTROL

COMPRESSOR CONTROL OPERATION

POWER UP

After a power up the controller checks the integrity of the parameters it maintains in EEROM memory. If this check fails the controller will go to the OFF MANUAL mode. Otherwise these parameters are used and the controller reverts to its previous mode.

All timers are reset so that the compressor cannot restart until the time after stop timer has elapsed (2 mins). This will give the operator sufficient time to change modes etc. The controller checks for any fault conditions and if any are present it displays the tripped status.

RUNNING

For all modes of operation status inputs and cut-out trip limits are continuously checked for fault conditions. If any are found then the compressor is immediately stopped and the appropriate trip mode indicated.

Over current and high discharge pressure capacity unloading operate in all modes.

MANUAL MODE.

In MANUAL mode, provided CAPACITY is selected, the capacity may be adjusted by operation of the RAISE/LOWER buttons.

A raise/lower request is actioned at one pulse every five seconds, the period dependant on the Loading delay value.

LOCAL AUTOMATIC MODE.

In LOCAL AUTOMATIC mode the capacity is adjusted dependant on the suction pressure being above or below the control band selected.

REMOTE AUTOMATIC MODE.

In remote automatic mode up to eight individual compressors are available to run. Compressors may be any combination of RCC-50 screws or RCC50 Pistons. One compressor always assumes overall control and is referred to as the Master. The Master compressor is selected on least runtime hours and Ready status.

If runtime hours are equal then priority is based on the compressors' unit number, compressor 1 having the highest priority.

When a compressor has established itself as Master, it uses the communications link to request status information from the other compressors. The action of transmitting by the Master will prevent any other REMOTE mode compressors from starting, regardless of suction pressure.

The status request command also contains the status information of all other compressors. This status information consists of:-

- i) Runtime hours
- ii) Capacity/Slide position
- iii) Compressor mode requires REMOTE automatic for control.
- iv) Compressor State - Ready, Waiting, At minimum, At maximum, Master, Load sharing, Over current, High Discharge.

When the suction pressure is above the control setpoint then the Master compressor will start. It will then attempt to maintain control by automatic adjustment of its capacity. If the suction pressure remains above the control band (+0.1 bar) such that the slide has reached 100% or the compressor has had an over current or high discharge back-off, then the stage up timer will be

started. The timer will be reset if the capacity falls below 100% or the suction pressure goes into or below the control band after a back-off.

Once the stage up timer elapses the Master compressor will stop transmitting, releasing control to the compressor with the next highest priority. As all compressors have runtime hours etc., each compressor waits for its priority time out period before becoming Master

The next compressor to establish its self as Master goes through the starting procedure. Whilst the suction pressure is above the control band the Master continues to raise its capacity. When the Master brings the suction pressure into or below the control band; then, provided its capacity is less than 100%, it will optimise capacity to improve efficiency. The Master will select a compressor to balance its capacity. To do this it selects the compressor with the greatest runtime hours, from the compressors that are at Maximum capacity. The Master then sets the Load sharing status flag of the required compressor.

This compressor then goes into capacity position regulation mode, selecting a capacity setpoint that divides the available capacity between the Master and itself. The load sharing compressor moves to its calculated capacity position, from 100%, by pulsing its lower valve. The Master compressor remains in suction pressure regulation mode, so as the pressure goes above the control band it will increase its capacity.

The load sharing compressor continues to adjust its capacity position setpoint as required.

The following situations may now occur:-

i) The refrigeration demand increases:-

Both compressors reach Maximum capacity and maintain this for the stage up period of the Master. The Master then removes the load sharing status, updates this status change to all other controllers and then stops transmitting so that the compressor with the next highest priority will take over.

ii) The refrigeration demand decreases:-

In this situation the load sharing compressor will not allow its capacity to go below 50%. The Master compressor will compensate by continuing to reduce its capacity. If the load sharing compressor maintains the 50% capacity for greater than its stage down delay it will remove its load sharing status, ramp its capacity down to minimum and then stop. The master compressor will maintain suction pressure regulation.

iii) Master compressor trips.

If the load sharing compressor is not fully loaded it will be given highest priority, revert to suction pressure regulation mode and become Master.

iv) Load sharing compressor trips.

The Master compressor maintains suction pressure regulation and if the previously stated conditions occur it will look for another compressor to load share with. Any mode changes made to the Master or load sharing compressor then the response is the same as for a trip condition.

STOPPING

The compressor may be stopped at any time by pressing the stop button. This will cause the compressor to unload to minimum and then stop. The controller will then display the MANUAL OFF mode.

MODES CHANGES

Once the compressor is running mode changes are allowed but they will have the following effects:-

i) **Automatic (Remote/Local) to Manual** -The capacity will remain at the last selected automatic position. The operator may then select capacity and use the raise/lower buttons as required.

ii) **Manual to Automatic LOCAL** - The controller will use suction pressure regulation to automatically adjust the capacity to match demand. If a start/stop refrigeration input is used then if stop is present the compressor will unload to minimum and then stop.

iii) **Manual to Automatic REMOTE** - If this is the only compressor running in REMOTE mode then it will go into suction pressure regulation mode, begin requesting status information and become the master. If another compressor is already master, it will ramp its capacity up to 100%.

TIMER SETPOINTS

Timer delays are displayed in the windows detailed below with selections 'type'= 'TIMERS and 'view'= 'LATEST VALUE'.

All timer delays count down to zero in tenths of a minute :-

Timers are adjusted using 'raise', 'lower', 'next', 'accept' when 'view'= setpoints



Adjustable timers are available for:-



Timer	Window	Range and description	
Restart	OIL2	2 to 9	starts per hour The controller restricts the compressor to the selected number of starts per hour.
After-stop	LOAD%	1 to 5mins	A minimum of one minutes is required after stop
C1 oil diff trip delay	OIL1	0.1 to 5mins	Delay before stopping compressor 1 on oil diff trip
C2 oil diff trip delay	OIL2	0.1 to 5mins	Delay before stopping compressor 2 on oil diff trip (or pump differential)
Stage up	SUCTION	1 to 12mins	Time compressor at 100% before allowing next compressor to start.
Stage down	DISCHARGE	1 to 10mins	Time compressor at minimum load before stopping
Loading delay	CAPACITY	0.1 to 5mins	Time between increasing/decreasing compressor loading solenoids
Fan stage delay	(no display)	0.1 to 5mins	Time between increasing/decreasing condenser fan stages.

SETUP

Compressor Settings

Unit Settings:

SUCTION OIL1
  Press "next" to sequence through Setup selections

DISCHARGE OIL2
  Press "raise" or "lower" to change settings

Press "accept" to accept settings

Unit Model 

- SSrL Single stage compressor with loading selection
- dSrL 2 stage compressor with loading selection

Multi-compressor control priority 

- YYYY = runH Priority run on hours
- LEAD Priority always highest
- LAg Priority always lowest
- StbY Only run if another has tripped

Multi-compressors On highway 

- Maximum number of controllers and temperature monitors on COM2 Control Highway
- nn = 1 - 8

Unit type 



- (definition of T5/P5 channel operation)
- YYYY = Std Standard RCC-50 operation



System number  nn = 1 - 80

Compressor number  nn = 01 - 06

Monitor Address  nnn = 1 - 255

Clock Settings

SUCTION OIL1
  Press "next" to sequence through Setup selections

DISCHARGE OIL2
  Press "raise" or "lower" to change settings

Press "accept" to accept settings



Real time clock  Real time hours nn = 0 to 23



 Real time mins nn = 0 to 59

System Settings

SUCTION	OIL1		Press “next” to sequence through Setup selections
DISCHARGE	OIL2		Press “raise” or “lower” to change settings
Starts per hour			Press “accept” to accept settings nn = 02 to 19
deadband			nn = 00 to 10 Capacity increase if Suction > setpoint + Deadband Capacity decrease if Suction < setpoint - Deadband
Fastband			nn = 00 to 10 Uses Cau,Cad Algorithms to reduce stage / loading delays if outside setpoint ± Fastband
Fastband Up Algorithm			n = 0 to 9 Compressor Up fastband Algorithm
Fastbanddown Algorithm			n = 0 to 9 Compressor Up fastband Algorithm
compressor Size			nn = 1 to 99
Number of Capacity loading control valves			Maximum number of capacity control valves nn = 1 - 4
Loading valve polarity			YYYY = LPoS Positive LnEg Negative
Trip input state			YYYY =TpoS Trip input state Positive tnEg Trip input state Negative
Refrigerant gas type			YYYY =r22 nH3 r404A
GLOBAL RS485 command action after all compressors tripped or OFF			CoFF = Cases OFF on highway section CnoA = Cases no Action on trip

Port Settings



SUCTION OIL1
  Press "next" to sequence through Setup selections



DISCHARGE OIL2
  Press "raise" or "lower" to change settings

Press "accept" to accept settings

Baud rate 
 YYYY = 9600 Baud rate settings for RS485 highway

Hours run



SUCTION OIL1
  Press "next" to sequence through Setup selections



DISCHARGE OIL2
  Press "raise" or "lower" to change settings

Press "accept" to accept settings





Hours run adjustment  nnn = -99 to 100

Analog



SUCTION OIL1
  Press "next" to sequence through Setup selections



DISCHARGE OIL2
  Press "raise" or "lower" to change settings

Press "accept" to accept settings

Pressure transducer type  nn = 0 to 255 P=00 0-100mV
 Slide voltage range  nn = 0 to 100 P=04 4-20mA
 Current transformer rating  nnn = 10 to 990 Amps C=00 0-10Vdc
 Maximum rated motor load  nnn = 10 to 990 Amps C=05 is normal setting

PT

SUCTION OIL
  Press "next" to sequence through Setup selections

DISCHARGE FILTER
  Press "raise" or "lower" to change settings

Press "accept" to accept settings



PT1000 or Pt100 selection  Hardware switch selection SW1 used to select PT1000 or PT100 probes being used for Temperature inputs AnIP 1.
 A1oF = normal PT1000 probes in use (sw=0)

etc A1on = PT100 probes (Motor winding temperatures) sw=1)
 A1nF = not fitted
 Temperature inputs AnIP 6
 A6oF = normal PT1000 probes in use
 A6on = PT100 probes (Motor winding temperatures)
 A6nF = not fitted

A6on

Test

SUCTION OIL1
  Press "next" to sequence through relays

DISCHARGE OIL2
  Press "accept" to toggle relay states

Relay R1  

Relay R2  

Relay R3  

etc

Relay R9  

Alarm relay  





LED 1 OFF ON

etc

LED 8 OFF ON

Tripped relay  

Done

SUCTION OIL1
 
 DISCHARGE OIL2
  Exit settings change and return to default compressor display

TRANSDUCER SETUP & CALIBRATION

TRANSDUCER SETUP

Transducer zero, scale and voltage ranges must be selected prior to calibration and is done as follows:-

Enter set-up as described in earlier section:

“ ” = “SYSTEM”
 “ ” = “SAFETY TRIPS”

SUCTION	OIL1
DISCHARGE	OIL2
DISCHARGE	OIL2
DISCHARGE	OIL2
DISCHARGE	OIL2
DISCHARGE	OIL2
DISCHARGE	OIL2

“” “ ”

“”

nn = P000 = 0-100mV transducer (P -zero) “”
 nn = P004 = 4-20mA transducer

nn = is slide voltage range 0-10V dc (C -scale) “”
 C 05 = 0-5V dc

nnn = is the current transformer rating (T - size) “”
 eg for a CT of 300:5 then nnn = 300

nnn = is the maximum rated motor (R - size) “”
 load in Amps
 eg For a 250Amp compressor nnn = 250

To change any ‘Anal’ (Analog) setting use the following procedure;

“” or “” until correct value is displayed

“” “”

SUCTION	OIL1
DISCHARGE	OIL2

“” “”

PRESSURE TRANSDUCER SETUP

MICROM Pressure transducers require the Setup-AnaL-P-xxx = P000.

SUCTION	OIL1	
■ ■ SE	■ ■ P ■	
DISCHARGE	OIL2	
■ ■ ■ ■	■ P ■ ■	nn = P 00 = 0-100mV transducer

4-20mA pressure transducers require a link LKP1-P5 to connect a 500 ohm resistor across the “+” and “-” terminals, and the selection Setup-AnaL P-xxx = P004.

SUCTION	OIL1	
■ ■ SE	■ ■ P ■	
DISCHARGE	OIL2	
■ ■ ■ ■	■ P ■ ■	nn = P 04 = 4-20mA transducer

CALIBRATION

4-20mA transducers are calibrated at the factory and should not need to be calibrated at site.

0-100mV transducers always require to be calibrated as follows:-

Select '**view**' = SYSTEM, '**type**' = PRESSURE with appropriate **SUCTION, DISCHARGE, OIL1, OIL2** pressure transducer vented to atmosphere (0 bar).

SUCTION	OIL1
■ ■ ■ ■	■ ■ ■ ■
DISCHARGE	OIL2
■ ■ ■ ■	■ ■ ■ ■

The pressure display in the appropriate window is the current error for each transducer at 0.0 bar.

Using '**next**' to select the required transducer, press '**raise**' or '**lower**' to make the displayed value zero and press '**accept**'.

The zero offset of the transducer is corrected if the displayed value is less than 1.5 bar.

With pressure at a normal operating value for the transducer ie 2.0 bar suction, 12-15 bar for discharge and oil, use '**raise**' and '**lower**' to adjust the value to match a calibrating gauge and press '**accept**'.

The scale offset of the transducer is corrected provided the displayed value is above 1.5 bar.

CAPACITY % SETUP

Slide voltage range must be selected prior to slide calibration.
On RCC systems slide calibration is not required so select :-

SEtuP-AnAL-C_term = C000

SUCTION	OIL1
■■SE	EUPE
DISCHARGE	OIL2
■■■■	E000

The Capacity % is then deduced from the state of the motor relays and loading/unloading valves active.

MOTOR LOAD % SETUP

IF a 300:5 current transformer is used then SEtuP-AnAL-tnnn = t300

press 'raise' or 'lower' until current transformer size is displayed then press 'accept'.
press 'next'

SUCTION	OIL1
■■SE	EUPE
DISCHARGE	OIL2
■■■■	E300

IF a 250 amp maximum rated motor is used then
SEtuP-AnAL-rnnn = r250

press 'raise' or 'lower' until the required motor rating is displayed then press 'accept'.

SUCTION	OIL1
■■SE	EUPE
DISCHARGE	OIL2
■■■■	R250

The load % zero and 100% settings can be marginally adjusted using
'view'=SYSTEM , 'type'=PRESSURE as for the capacity % above.

COMMUNICATIONS

The RCC-50 has two RS485 communication links Com 1 and Com2.

Com 1 on TB4 is the RS485 Monitor Highway link to a central supervisory system such as Guardian 'Consultant'.

COM1 RS485 link has now been changed to Modbus RTU protocol and no longer supports the former Guardian AGT protocol for RCC40 and SCC40 controllers.

Com2 on TB11 is the RS485 Control Highway link to other Guardian RCC-50 and SCC-50 Compressors in the same pack system so that they can arbitrate on inter-compressor master control strategy.

A maximum of eight RCC-50 or SCC-50 controllers may be fitted to a control highway system for the same suction control group.

The polling of COM2 RS485 link has now been changed and is no longer compatible with the former RCC-40 and SCC-50 protocol for inter-compressor communications.

MONITOR HIGHWAY MODBUS COMMUNICATIONS (COM1)

Remote monitoring, modification and control of the compressor system via COM1 two-wire serial link (RS485) may be provided using the GUARDIAN 'Consultant'.

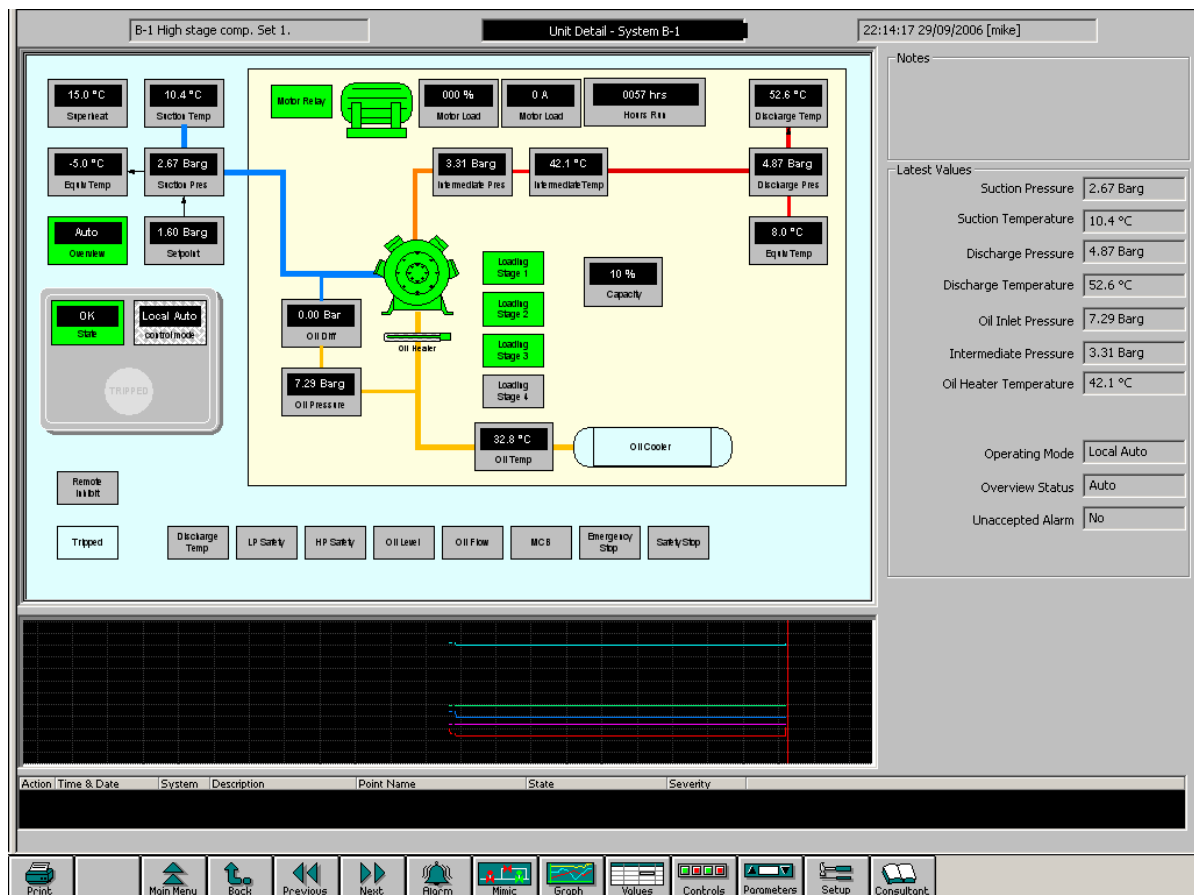

This IBM compatible PC terminal provides displays of latest values, control and alarm settings, timers and compressor status together with daily printouts of pressure and temperature graphs, alarm and trip messages.

Communication facilities are available for interrogation of temperatures, status and modification / display of setpoints, limits and timeclock settings. All communication is via a daisy chain RS485 link which connects all GUARDIAN controllers units in series.

Communication commands and replies are now in **Modbus Protocol** and checked for parity and block length and automatically re-transmit if errors are detected.

Each GUARDIAN controller has a unique unit number address A which is used to select the appropriate unit for interrogation or modification.

GUARDIAN RCC-50 controllers are inactive until they are addressed.

MODBUS RTU Communication commands available for a supervisory PLC or PC or Guardian 'Consultant' are:-

- a) Transmit Values which replies with address plus latest pressure, temperature slide and load values, time, trip states, relay states and internal status.
- b) Transmit Setpoints which replies with individual setpoints and limits.
- c) Receive setpoints and limit settings with latest setpoint values.

The Register Allocation and Format types for the RCC-50 point data is as follows

Modbus Addressed parameters are read using function code 03, Read Holding registers, and are written to by using function code 16, Pre-set Multiple registers.

CONTROL HIGHWAY COMMUNICATIONS (COM2)

When Remote Auto is selected for a compressor, Multi-Compressor pack control for all compressors in the same suction group system is performed as in Remote Automatic page 22 and **Error! Reference source not found.** page 28.

This control relies on inter-compressor RS485 communications on COM2 using a Guardian internal protocol.

A maximum of eight controllers and monitors may be fitted to a control highway system.

The maximum number of compressors on the COM2 Control highway and the control highway address of the unit must be setup as detailed in **Error! Reference source not found.** page 31.

A two-wire screened communication cable must be connected to all RCC-50 controllers and temperature monitors on the same temperature control system as follows.

Different Termination resistor links must be selected for the first, the last and all middle controllers as indicated.

Suction Group Control Communications

Internal Communications between Compressors in a suction group

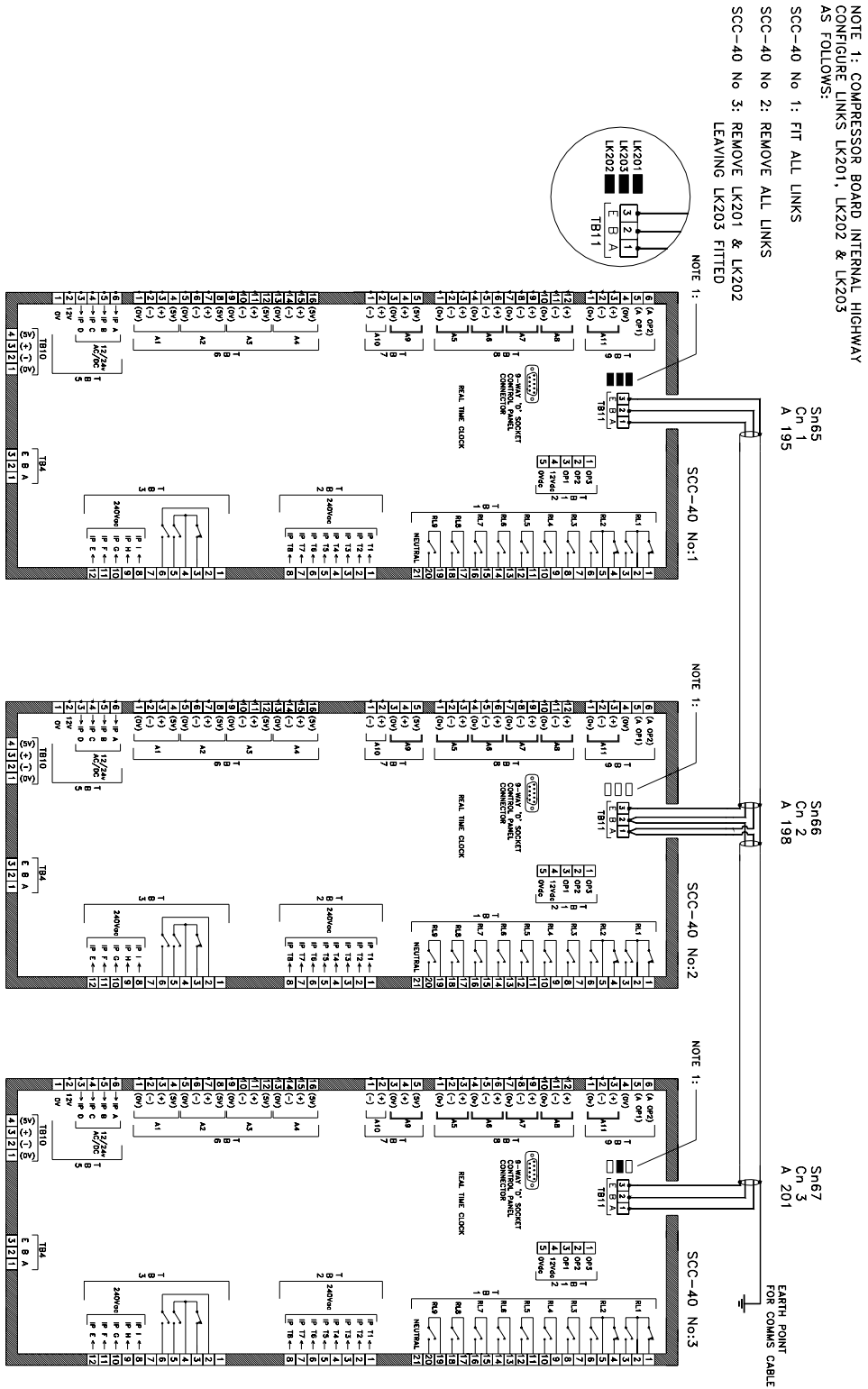

Setup / Commissioning Parameters

	units	Actual setting	default	Min setting	Max setting
U n r l					
Model type SSrL, dSrL		<i>dSrL</i>		SSrL	dSrL
Remote control mode runH/LEAd/LAg/StbY (C1LF,C1L4)				runH	StbY
Number of compressors in same suction group		<i>nC</i>		<i>nC 1</i>	<i>nC 8</i>
Variations (always set to Std.)		<i>Std.</i>		<i>Std.</i>	
System pack number		<i>Sn</i>		Sn01	Sn80
Compressor number		<i>Cn</i>		Cn01	Cn06
Monitor Address		<i>A</i>		A 01	A255

r H					
Motor starts per hour		<i>rH</i>		rH00	rH23
Suction deadband	bar	<i>rt</i>		rt00	rt59

S S S S					
Motor starts per hour		<i>SH</i>		SH02	SH19
Suction deadband	bar	<i>db</i>		db00	db10
Suction Fast response band	bar	<i>Fb</i>		Fb0.1	Fb5.0
Suction Control Fast Algorithm stage up		<i>CAu</i>		FAu0	FAu9
Suction Control Fast Algorithm stage down		<i>CAd</i>		FAd0	FAd9
Compressor size	A	<i>C1</i>		1C00	1C99
Number of Loading Valves		<i>nL</i>		nL 0	nL 4
LpoS/Lneg loading valve polarity		<i>L</i>		Lneg	LPoS
Trip inputs positive/negative to trip		<i>t</i>		tPoS	tneg
Gas type (R22, Ammonia NH3 or 404A)				r22	404A
Action on trip: CnoA no action on trip Coff on highway section		<i>C</i>		CnoA	CoFF

P o r e					
Communications baud rate				9600	1200

H r u n					
Hours run adjustment (compressor No 1)		<i>H</i>		H -99	H100

F A N S (not used on RCC50)					
Maximum number of condenser fans		<i>Fn</i>		Fn00	Fn05
Fan control deadband	bar	<i>db</i>		db0.1	db5.0
Fast response band	bar	<i>Fb</i>		Fb0.1	Fb5.0
Fans Algorithm stage up		<i>FAu</i>		FAu0	FAu9
Fans Algorithm stage down		<i>FAd</i>		FAd0	FAd9
Fans stage delay	mins	<i>Fd</i>		Fb0.1	Fb3.0

P T					
Pressure transducer type P=04 4-20mA		<i>P</i>		P 00	P255
Slide scale (0 = not used on RCC50)		<i>C</i>		C 00	C100
Load transformer rating	Amp	<i>t</i>		t000	t990
Motor maximum rating	Amp	<i>r</i>		t000	t990

P E					
Temperature probe PT100 / Pt1000 selection on bit switches A1 to A6 (AxOF, AxOn, AxnF {x=1to 6})		<i>A1oF etc. A6on</i>		P 00	P255

Display Window	'type' selection	'view' selection	Settings	unit	Actual Setting	Default Setting	Min Setting	Max Setting
PRESSURES								
SUCTION	PRESSURE	SETPOINT	Suction Pressure setpoint	bar			-0.6b	5.0b
DISCHARGE	PRESSURE	SETPOINT	Condenser fans setpoint	bar			5.0b	20.0b
OIL2	PRESSURE	SETPOINT	CIL4 Intermediate Setpoint	bar			0.0o	5.0o
LOAD	PRESSURE	SETPOINT	Stop loading at > load	%			50	99
SUCTION	PRESSURE	LOW ALARM	Stop compressor on low suction	bar			-1.0b	5.0b
CAPACITY	PRESSURE	LOW ALARM		%				
SUCTION	PRESSURE	HIGH ALARM	hi-alarm suction pressure	bar			0.0b	20.0b
DISCHARGE	PRESSURE	HIGH ALARM	hi-alarm disc pressure (unload)	bar			0.0b	23.0b
CAPACITY	PRESSURE	HIGH ALARM		%				
LOAD	PRESSURE	HIGH ALARM	Start unloading at >load	%			75	100
SUCTION	PRESSURE	LOW TRIP	lo-trip suction pressure	bar			-1.0b	5.0b
LOAD	PRESSURE	LOW TRIP	lo-trip motor current	%				
SUCTION	PRESSURE	HIGH TRIP	hi-trip suction pressure	bar			0.0b	20.0b
DISCHARGE	PRESSURE	HIGH TRIP	hi-trip discharge pressure	bar			0.0b	23.0b
TEMPERATURES								
OIL2	TEMP	LOW ALARM	CIL4 Intermediate Setpoint	°C			0.0o	5.0o
SUCTION	TEMP	HIGH ALARM	hi-alarm suction temperature	°C			-40c	90c
DISCHARGE	TEMP	HIGH ALARM	hi-alarm discharge temperature	°C			40c	170c
OIL1	TEMP	HIGH ALARM	hi-alarm oil temperature	°C				
SUCTION	TEMP	HIGH TRIP	hi-trip suction temperature	°C			-46c	100c
DISCHARGE	TEMP	HIGH TRIP	hi-trip discharge temperature	°C			40c	170c
OIL1	TEMP	HIGH TRIP	hi-trip C1 oil temperature	°C				
DIFFERENTIALS								
SUCTION	DIFF	LOW ALARM	lo-alarm suction superheat	°C			-46c	20c
OIL1	DIFF	LOW ALARM	lo-alarm C1 oil-suction diff	bar			-1.0b	5.0b
OIL2	DIFF	LOW ALARM	lo-alarm C2 oil-suction diff	bar			-1.0b	5.0b
SUCTION	DIFF	HIGH ALARM	hi-alarm suction superheat	°C			05c	100c
SUCTION	DIFF	LOW TRIP	lo-trip suction superheat	°C			-46c	30c
OIL1	DIFF	LOW TRIP	lo-trip oil diff pressure	bar			-1.0b	5.0b
OIL2	DIFF	LOW TRIP	lo-trip oil 2 diff	bar			-1.0b	5.0b
SUCTION	DIFF	HIGH TRIP	hi-trip suction diff temperature	°C			-40c	100c
TIMERS								
SUCTION	TIMERS	SETPOINT	stage up delay (u)	mins			0.1u	12.5u
DISCHARGE	TIMERS	SETPOINT	stage down delay (d)	mins			0.1d	10.0d
OIL1	TIMERS	SETPOINT	C1 oil diff delay (p)	mins			0.2P	5.0P
OIL2	TIMERS	SETPOINT	C2 oil diff delay (o)	mins			0.0o	5.0o
CAPACITY	TIMERS	SETPOINT	Loading valve delay	mins			0.1	5.0
LOAD	TIMERS	SETPOINT	delay after stop	mins			0.3	12.5

Settings display and change facilities.

‘view’ LATEST VALUE							
‘type’	SUCTION	DISCHARGE	OIL1	OIL2	COMP No	CAPACITY%	LOAD%
PRESSURE	A1 bar	A2 bar	A3 bar	A4 bar	Cn	A9 %	A10 %
TEMPERATURE	A5 °C	A6 °C			Cn	A9 %	A10 %
EQUIV TEMP	A11 °C	A12 °C			Cn	A9 %	A10 %
DIFFERENTIAL	A11-A5 bar	A2-A1 bar	A3-A1 bar	A4-A1 bar	Cn	A9 %	A10 %
HOURS RUN	64		000Hrs		Cn	A9 %	A10 %
TIMERS (mins)	stage-up	stage-down	C1 diff	C2 diff	Cn	A9 %	A10 %
SAFETY TRIPSdependent on model.....				Cn	A9 %	A10 %

‘view’ SETPOINTS							
‘type’	SUCTION	DISCHARGE	OIL1	OIL2	COMP No	CAPACITY%	LOAD%
PRESSURE	Comprs	Fans	Intermediate				stop-raise
TEMPERATURE							stop-raise
EQUIV TEMP							stop-raise
DIFFERENTIAL							stop-raise
HOURS RUN							stop-raise
TIMERS (mins)	stage-up	stage-down	C1 diff	C2 diff		min run %	stop-raise
SAFETY TRIPS							stop-raise

‘view’ LOW ALARM							
‘type’	SUCTION	DISCHARGE	OIL1	OIL2	COMP No	CAPACITY%	LOAD%
PRESSURE	yes						
TEMPERATURE				yes			
EQUIV TEMP							
DIFFERENTIAL			<1.5 bar				
HOURS RUN							
TIMERS (mins)							
SAFETY TRIPS							

‘view’ HIGH ALARM							
‘type’	SUCTION	DISCHARGE	OIL1	OIL2	COMP No	CAPACITY%	LOAD%
PRESSURE	yes	yes	yes	1.5			start-lower
TEMPERATURE	yes	motor-inhibit	yes				start-lower
EQUIV TEMP	yes						start-lower
DIFFERENTIAL	yes						start-lower
HOURS RUN							start-lower
TIMERS (mins)							start-lower
SAFETY TRIPS							start-lower

‘view’ LOW TRIP							
‘type’	SUCTION	DISCHARGE	OIL1	OIL2	COMP No	CAPACITY%	LOAD%
PRESSURE	stop-compr						
TEMPERATURE				yes			
EQUIV TEMP							
DIFFERENTIAL			<1.0 bar				
HOURS RUN							
TIMERS (mins)							
SAFETY TRIPS	SP min						

‘view’ HIGH TRIP							
‘type’	SUCTION	DISCHARGE	OIL1	OIL2	COMP No	CAPACITY%	LOAD%

PRESSURE	yes			>2.3 bar			
TEMPERATURE	yes	start-lower	yes				
EQUIV TEMP							
DIFFERENTIAL							
HOURS RUN							
TIMERS (mins)							
SAFETY TRIPS	SP max						

'view'	SYSTEM						
'type'	SUCTION	DISCHARGE	OIL1	OIL2	COMP No	CAPACITY%	LOAD%
PRESSURE	cal - A1	cal - A2	cal - A3	cal - A4	Cn 1 to 4	cal A10	max load
TEMPERATURE							
EQUIV TEMP							
DIFFERENTIAL							
HOURS RUN	adjust	adjust					
TIMERS (mins)	raise_w	raise_w					
SAFETY TRIPS							

RCC-50 Enclosure wiring: for trips negative

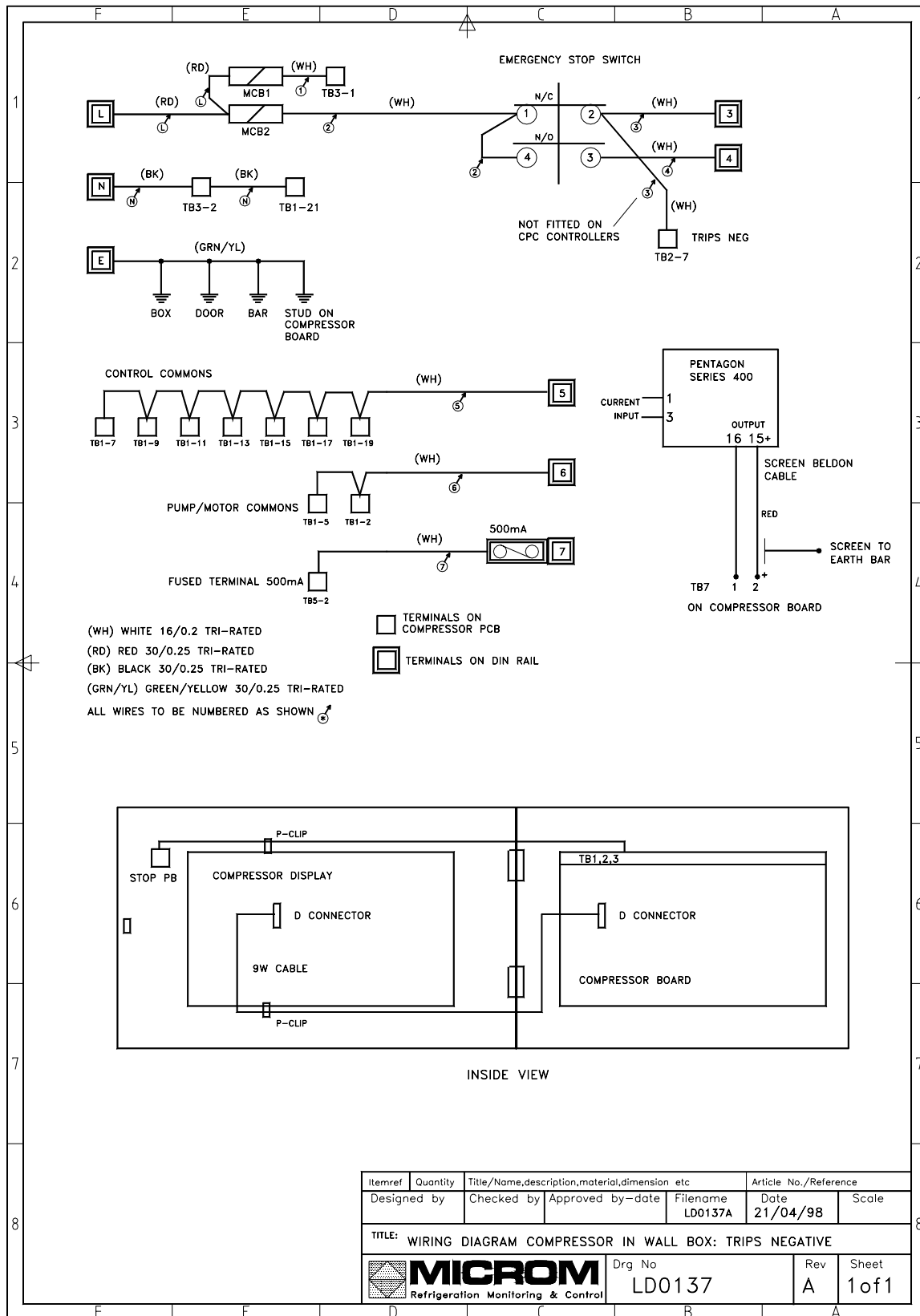

RCC-50 Enclosure wiring: for trips positive.

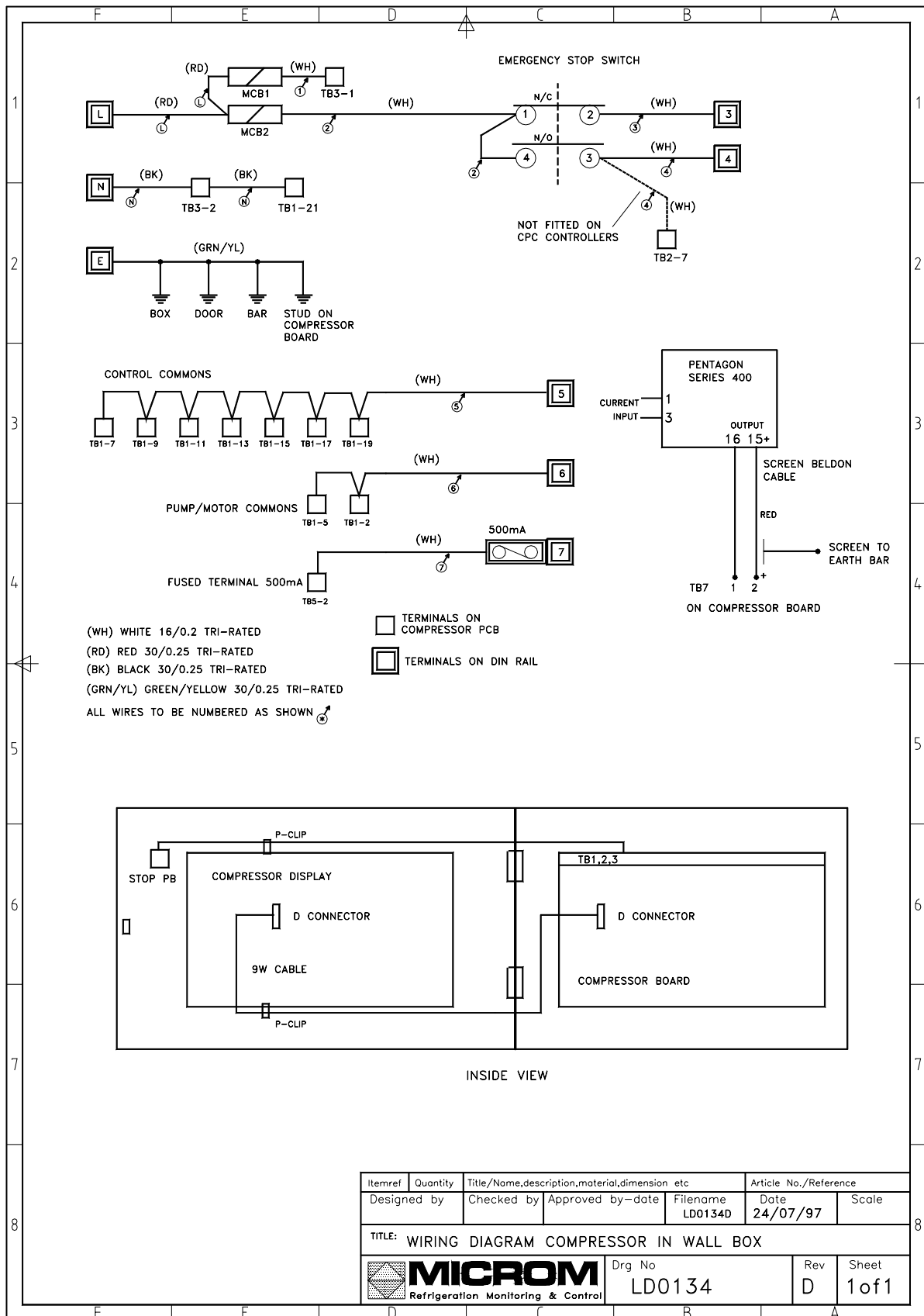

Itemref	Quantity	Title/Name,description,material,dimension etc	Article No./Reference		
Designed by	Checked by	Approved by-date	Filename	Date	Scale
			LD0134D	24/07/97	
TITLE: WIRING DIAGRAM COMPRESSOR IN WALL BOX					
		Drg No	Rev	Sheet	
Refrigeration Monitoring & Control		LD0134	D	1 of 1	

FITTING NEW EPROM

**NOTE POSITION BEFORE REMOVAL.
ACTUAL LOCATION MAY BE REVERSED**

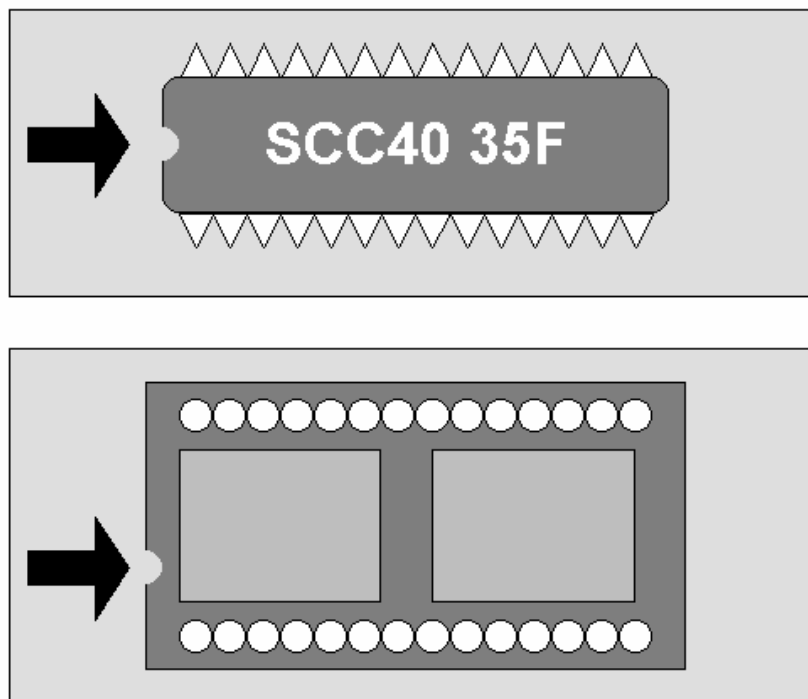

**CORRECT POSITIONING OF EPROM
ALIGN INDICATED INDENTS**

Index

Accept	24	OVERVIEW	8
ALARM ACCEPT AND RESET	25	Port Settings	33
ALARM INPUTS	17	POWER UP	28
Analog	33	PRESSURE TRANSDUCER SETUP	36
Available unit model (RCC-40)	10	PT	33
BUTTON OPERATION SHORTHAND	5	Pushbuttons.	9
CAPACITY % SETUP	37	raise.....	24
COMMUNICATIONS	38	Raise	23
COMPRESSOR CONTROL OPERATION	28	<i>RCC-40 'C1L4' Input/Output Signals</i>	11
Compressor Settings.....	31	RCC40 PANEL LAYOUT	16
CONFIGURE UNIT MODEL, SYSTEM No & ADDRESS	6	RCC-40 Termination Wiring - 'C1L4' model selection.....	14, 15
CONTROL	28	Relay output status.....	18
CONTROL MODES.....	27	REMOTE AUTOMATIC	27
CONTROL PUSHBUTTON OPERATION	22	RESET	23
Control status displays.	18	RS485 Communications.....	7
DISPLAY INDICATIONS	17	RUNNING.....	28
DISPLAY PUSHBUTTON OPERATION	20	SAFETY TRIP INDICATIONS	19
Displays.....	9	SCC-50 Enclosure wiring: for trips negative	45
Done.....	34	SCC-50 Enclosure wiring: for trips positive.....	46
Enter Passcode	6	Select System No and Address.....	7
FITTING NEW EPROM	47	Select Unit Model	6
Functions.....	8	SETPOINTS	26
GENERAL	27	SETTINGS CHANGE PUSHBUTTON OPERATION.....	24
GENERAL SPECIFICATION.....	10	SETUP	31
GETTING STARTED.....	4	start	23
HARDWARE CHECKS	5	stop.....	23
Hours run.....	33	STOPPING	30
Inputs.....	18	System Settings	32
LED LAMPS.	17	SYSTEM STATUS DISPLAYS	17
LOCAL AUTOMATIC	27	Test	34
Local Communications	40	TIMER SETPOINTS.....	30
Lower.....	23, 24	TRANSDUCER SETUP & CALIBRATION	35
MANUAL	27	TRANSDUCER SETUP	35
mode	22	Trip inputs.....	19
Mode-AUTOMATIC	22	type.....	20
Mode-MANUAL	22	UNIT MODELS	8
MODES CHANGES	30	Unit Settings:.....	31
MOTOR LOAD % SETUP	37	view	20
next.....	24		
OPERATION	16		