

GUARDIAN

SCC-50(AQUAT)

Screw Compressor Controller

- Compressor status monitor with pressure, temperature, slide and load displays
- Control by suction or remote pressure setpoint
- Control by suction equivalent or chiller temperature setpoint
- Alarm and trip monitoring with optional motor winding temperatures
- Compressor, pump, slide and speed control
- Economiser, heater and liquid injection control
- Automatic volumetric slide control via optional stepper motor
- Multiple compressor system control
- Local panel operation and set-up with optional remote pushbuttons operation
- MODBUS communications for remote monitoring and set-up
- xx
- .

Operation and Setup Manual

GUARDIAN SCC-50 Screw Compressor Controllers provide suction pressure setpoint control and alarm monitoring for one screw compressor. Alternatively the unit may be set-up to control on water chiller, glycol chiller or equivalent temperature.

The SCC50 unit supersedes its SCC40 predecessor and provides increased response, input/output signal capability, control and communication facilities. The SCC50 still uses the SCC40 operator control Panel.

GUARDIAN

Tel. +44 (0) 1270 760599

Fax. +44 (0) 1270 766804

Email: sales@Guardian-controls.com

www.Guardian-controls.com

Contents

SCC-50	1
GETTING STARTED	5
BUTTON OPERATION SHORTHAND	6
HARDWARE CONFIGURATION CHECKS	6
CONFIGURE UNIT MODEL, SYSTEM No & ADDRESS	7
Enter Passcode.....	7
Select Unit Model.....	7
Select System No and Address.....	8
RS485 Communications.....	8
UNIT MODELS	9
OVERVIEW	9
Functions.....	9
Displays.....	10
Pushbuttons.....	10
GENERAL SPECIFICATION	12
Consultant Mimic Format SCC-50 Standard	13
AVAILABLE UNIT MODELS	14
SCC-50 Input/Output Signals.....	15
SCC50 Fuse Ratings.....	16
SCC50 FUSES and LED LAYOUT.....	17
SCC-50 Termination Wiring -.....	18
Old Model SCC-40 Termination Wiring -.....	19
SCC50-Auto VI Stepper Motor wiring.....	20
SCC50 8-X Extension - Terminal Connections for Hazardous Area Panel.....	21
SCC-50 Motor Monitor Temperature Signals.....	22
SCC-50 Motor Monitor Temperature Wiring.....	22
OPERATION	23
SCC40 PANEL LAYOUT	23
LED LAMPS.....	24
SYSTEM STATUS DISPLAYS.....	25
SAFETY TRIP INDICATIONS.....	29
DISPLAY PUSHBUTTON OPERATION.....	30
'view'.....	30
'type'.....	30
CONTROL PUSHBUTTON OPERATION	32
"mode".....	32
"Mode-MANUAL".....	32
"Mode-AUTOMATIC".....	32
"RESET".....	32
"Call Frig Engineer".....	33
"stop".....	33
"start".....	33
"Lower".....	33
"Raise".....	33
SETTINGS CHANGE PUSHBUTTON OPERATION	34
"next".....	34
"Accept".....	34
"raise".....	34
"Lower".....	34

“RESET”	34
ALARM ACCEPT AND RESET PUSHBUTTON OPERATION	35
SETPOINTS	37
CONTROL MODES	39
GENERAL	39
i) MANUAL	39
ii) LOCAL AUTOMATIC.....	39
iii) REMOTE AUTOMATIC	39
SCC50 8-X EXTERNAL CONTROL PANEL OPERATION	40
CONTROL.....	42
COMPRESSOR CONTROL OPERATION.....	42
POWER UP	42
READY/WAITING	42
STARTING	43
RUNNING	44
STOPPING.....	46
MODES CHANGES	46
TWO SPEED MOTOR CONTROL	47
MANUAL MODE 2-SPEED	47
VARIABLE SPEED MOTOR CONTROL	47
TWO COMPRESSOR-SINGLE MOTOR OPERATION	49
SET-UP OF AUTO VI.....	50
Auto VI Operation:	50
Procedure	51
Auto VI Commissioning Parameters.....	52
TIMER SETPOINTS	54
SETUP	56
Compressor Settings.....	56
Unit Settings:.....	56
System Settings	58
xxxxx	59
Analog	60
PT.....	60
Test	61
Done.....	61
TWO SPEED MOTOR CONTROL SELECTION	62
MOTOR TEMPERATURE MONITOR SETUP	63
Motor Temperature Monitor Setup Selection	63
Motor Temperature Monitor DISPLAY & ALARM LIMITS	64
TRANSDUCER SETUP & CALIBRATION	65
COMMUNICATIONS.....	69
MONITOR HIGHWAY MODBUS COMMUNICATIONS.....	69
MODBUS REGISTER ALLOCATION	70
MODBUS FORMAT TYPES.....	71
MODBUS SYSTEM SETTINGS ADDRESS	72
CONTROL HIGHWAY COMMUNICATIONS	73
Control Highway Communication Wiring.....	74
MAIN SET-UP/ COMMISSIONING PARAMETERS	74
Setup / Commissioning Parameters	79
PRESSURES	79
TEMPERATURES.....	80

EQUIVALENTS	80
DIFFERENTIALS	81
TIMERS.....	82
Settings display and change facilities.....	83
SCC-50 Enclosure wiring: for trips negative.....	85
SCC-50 Enclosure wiring: for trips positive.....	86
Standard Wallbox Internal wiring.....	87
Standard SCC 40 Drawing	88
FITTING NEW EPROM	89
Index	90

GETTING STARTED

Guardian Controllers provide refrigeration engineers with

- **ACCURATE CONTROL**
- **ULTIMATE FLEXIBILITY**
- **ASSURED MONITORING**
- **RELIABLE ALARMS**



This manual provides refrigeration designers, installers, service mechanics and supermarket personnel with the necessary information to achieve the above objectives.

All users require to know a few basic facts about this controller before successfully starting to perform their design, commissioning, maintenance or operating functions.

- a) All GUARDIAN controllers need to be set up with a unit model selection and other basic settings for setpoints, timers and addresses.
- b) The shorthand used in the following chapters for concisely expressing button pressing and selection sequences to do all this set-up needs to be understood.
- c) Mains power input voltage and hardware switch and link option selections (if any are required) must correspond to the selected unit model configuration.
- d) Since each controller can be configured in a number of different ways to perform flexible refrigeration control then an understanding of how to find out what unit model is currently selected, what it does and how it is connected, is also necessary.

BUTTON OPERATION SHORTHAND

To assist in easy set-up of control setpoints, delays, timers and other configuration settings, the sequence of button presses and subsequent displays will be shown in this handbook as below:

- ii) A button symbol, followed by text means press that button. “ accept”
- iii) A double button, followed by text means press that button repeatedly. “ raise”
- iv) A display box with the window above it shows the result of the last button press on the display.



Means the display alternately flashes between identifier and trip message

HARDWARE CONFIGURATION CHECKS

Prior to switching on the GUARDIAN controller check that the hardware unit is the correct type for the incoming mains voltage.

When satisfied that the correct type of controller is available then the following checks should be made prior to controller installation or replacement

- a) Ensure mains supply is wired correctly to the appropriate TERMINAL WIRING drawing for the model selected.
- b) Ensure that any transducer selector switches specified on the TERMINAL WIRING diagram are in the correct state.
- c) Ensure any shorting link selector pins specified on the TERMINAL WIRING diagram are correctly fitted.
- d) Ensure that probes are wired to the terminal WIRING DIAGRAM and the correct type of thermistor or pressure transducer probes are fitted.
- e) The RS485 highway connections (if required) are wired to the correct terminals and the screen drain wire is continuous to earth.

CONFIGURE UNIT MODEL, SYSTEM No & ADDRESS

Enter Passcode

Before any permanent change of controller settings are made then the correct entry of the appropriate passcode is necessary.

The settings available for change on each passcode are as follows; Passcode

Passcode level 1	setpoints, low & high alarm settings	07
Passcode level 2	low & high trip settings and all level 1	09
Passcode level 3	system settings and levels 1 & 2	15

Enter passcode 15

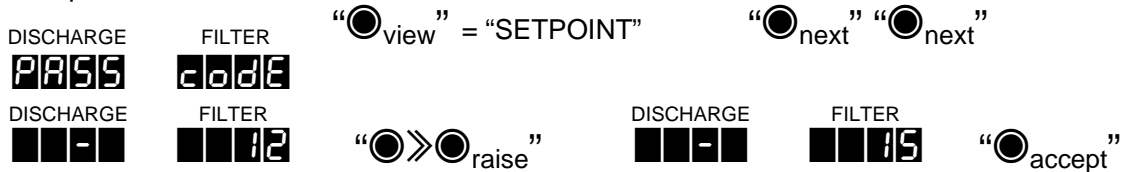

“view” = “SETPOINT” “next” “next”

“raise” “accept”

Press “view” to select “SETPOINT”, then press the “next” button twice to enter the passcode settings.

Press “raise” repeatedly until passcode 15 is selected and then press “accept”

Select Unit Model

Enter Passcode as button sequence above.

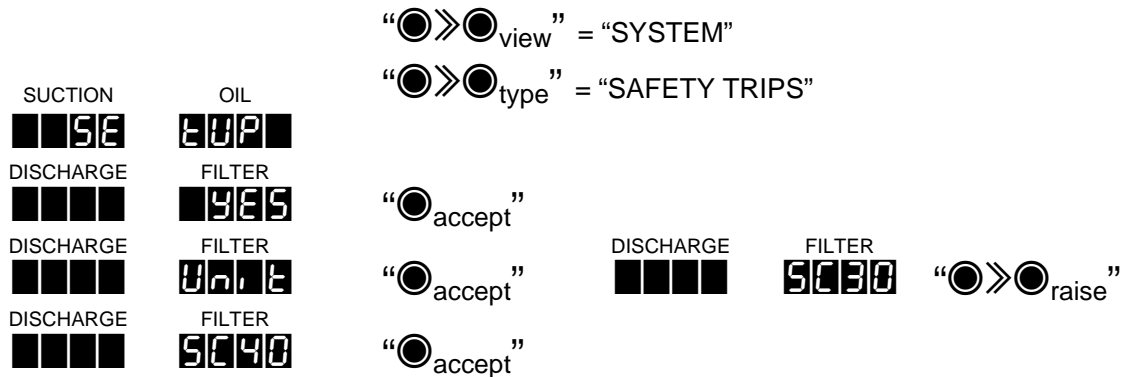

“view” = “SYSTEM”

“type” = “SAFETY TRIPS”

“accept”

“accept” “raise”

“accept”

Press ‘view’ repeatedly until ‘SYSTEM’ is selected.

Press ‘type’ repeatedly until ‘SAFETY TRIPS’ is selected. Press ‘accept’

‘Unit’ is displayed press ‘accept’

Display shows unit model currently selected which may be wrong.

Press ‘raise’ repeatedly until correct model is displayed (e.g.SC30) and then press ‘accept’ which causes the display to wink briefly and display the new unit model selection (e.g SC40)

Select System No and Address

e.g. setup unit for system 65 compressor number 1 at address 195

Enter setup as button sequence as above

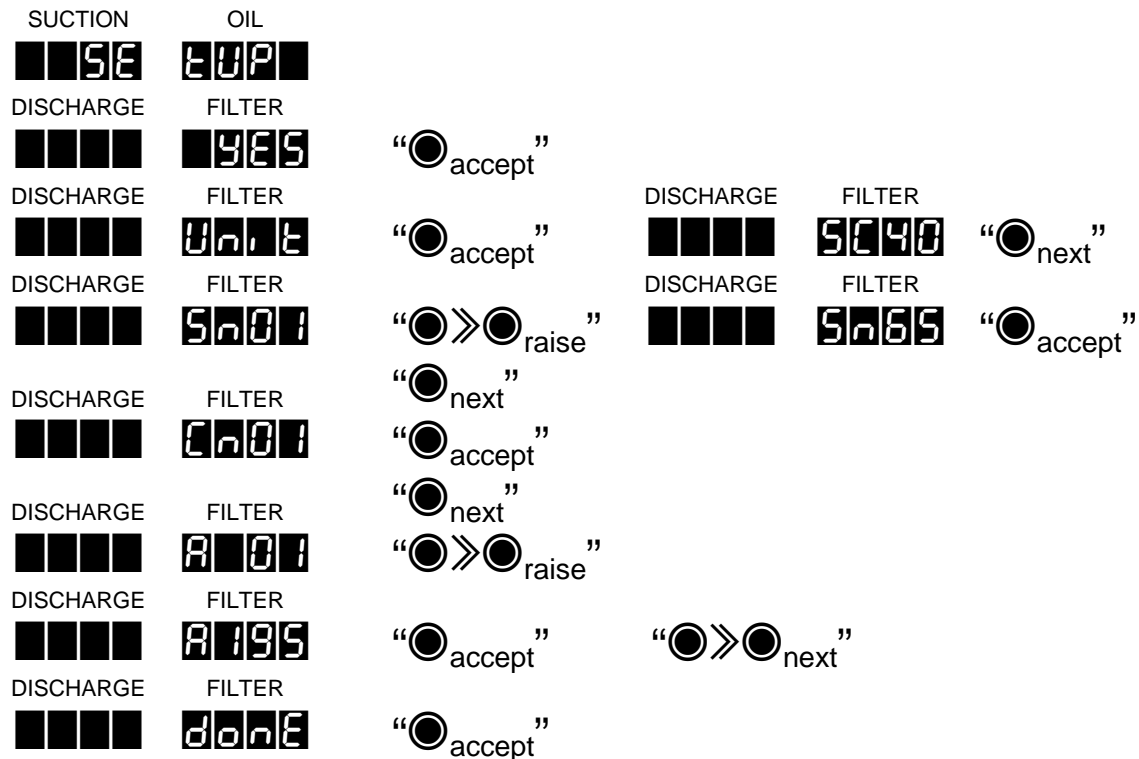

RS485 Communications

When the correct system number, case/compressor number and highway address have been entered as above then the controller can communicate with the GUARDIAN Consultant Terminal PC for central alarm monitoring and temperature display. Control setpoints, defrost times and alarm limits may then be sent to the controller from the PC.

For further details see page 63

UNIT MODELS

Guardian controllers may be configured in a number of different ways dependent on unit model selection. Each unit model fulfils a different refrigeration temperature monitoring and control requirement. In order to perform the required refrigeration control then each model has different uses for the controller's input output signals. This section gives details of all the model variations available for the controller and the way to connect the wiring to the plant devices and measuring transducers.

OVERVIEW

Functions

The GUARDIAN SCC-50 controller provides facilities for:-

MONITORING

Measurement of pressures, temperatures, load and slide inputs for control, alarm and trip display

Calculation of differential pressures and superheat temperatures for control, alarm and trip display.

Detection of digital input states or safety trip inputs.

ALARMS

Detection after a preset guardtime of pressure and temperature High/Low alarms when the compressor is in operation. Alarms are indicated by alternating a **Hi** or **Lo** message on the appropriate temperature or pressure display.

TRIPS

Detection of pressure and temperature High/Low trips which stop the compressor. Trips are indicated by the flashing red TRIPPED lamp and an alternating 'TRIP' message on the appropriate temperature/pressure display.

All measurement values are frozen after detection of a trip condition. This facility provides information on the compressor state, pressures and temperatures when the trip occurred until after the RESET pushbutton has been pressed.

Detection of safety trips which stop the compressor.

Trips are indicated by the flashing red TRIPPED lamp and an appropriate message.

Trips vary dependent on pack model configuration.

ie :- **L.P.**, **H.P.**, **LEU**, **FLo** alternating with a **TRIP** message on the appropriate display.

CONTROLS

Oil pump, motor and economiser startup and run sequences using preset timers and limits
Compressor status is indicated by LED lamps on the control panel.

Compressor capacity slide valve raise / lower control dependent on suction pressure or slide control setpoint. The slide valve is automatically lowered when over-current limit or high discharge pressure are detected or the compressor is stopped.

Suction pressure or slide control initiation of other compressors in the system via a RS485 link when in REMOTE mode.

Oil heater and liquid injection control on oil sump and discharge temperatures.

VI control using internal stepper motor control signals, condenser FAN control and extra injection selection

Displays

i). SUCTION, DISCHARGE, OIL & FILTER.

SUCTION

OIL

4-digit 7-segment LED displays for display of measurements setpoints/limits for temperatures and pressures

DISCHARGE

FILTER

The contents change dependent on 'view' and 'type' selections

ii). CAPACITY%.

CAPACITY%

3-digit 7-segment LED displays for display of loading timers and capacity.

iii). MOTOR LOADING%.

MOTOR LOAD%

3-digit 7-segment LED displays for display of timers and motor load.

iv). COMPRESSOR No.

No

1-digit 7-segment LED display

Pushbuttons.

All pushbuttons are embossed, tactile membrane switches.

start, stop, raise & lower	used to control compressors when in manual mode.
RESET	used after a trip to reset the compressor.
Mode, view & type	used in conjunction with appropriate LED displays to select control, display or settings change facilities.
accept, next	used in conjunction with raise, lower and appropriate LED displays during setpoint and limit settings changes.

Unaccepted alarms and trips are acknowledged by pressing accept.

Pushbuttons on the local control panel permit operator display of setpoints, pressures, temperatures, alarm and trip settings and compressor runhours and status. Setpoints, alarm and trip settings may be changed from the panel after entry of the appropriate passcode.

The compressor may be selected to operate in one of three control modes:-

MANUAL, LOCAL or REMOTE MODES.

Safety interlocks, alarm, trip, startup and shutdown sequence controls are automatic in all three modes.

In **MANUAL** mode, the each compressor may be individually started and stopped and the pack capacity raised and lowered by operator pushbutton control from the local panel.

In **LOCAL** automatic mode, the compressor is started and stopped under control of the suction pressure setpoint.

REMOTE automatic mode allows up to eight RCC-40 units to be connected via a two-wire communication link (RS485) to provide 8-unit system control.

GENERAL SPECIFICATION

Power	110 or 230 Vac 50 Hz 30VA (dependent on model type)
Operation	0 to 50°C
Approx. Dimensions:	
Control panel:	300 x 220mm
Control unit:	300 x 230 x 90mm

The GUARDIAN SCC-50 control unit comprises a printed circuit board xx for mounting at the rear of the compressor pack control panel with the display unit mounted on the door and has overall dimensions:- 300 x 230 x 90mm.

The unit is fitted with two-part screw-clamp terminals for the connection of the appropriate input/output signals. (See input/output section)

The GUARDIAN SCC40 control panel comprises a membrane, pushbutton and display panel mounted on the front of the control unit.

The membrane front panel has a Black background with white lettering and blue buttons with dimensions 300x220mm.

A display panel membrane with text in Chinese Characters is now available.

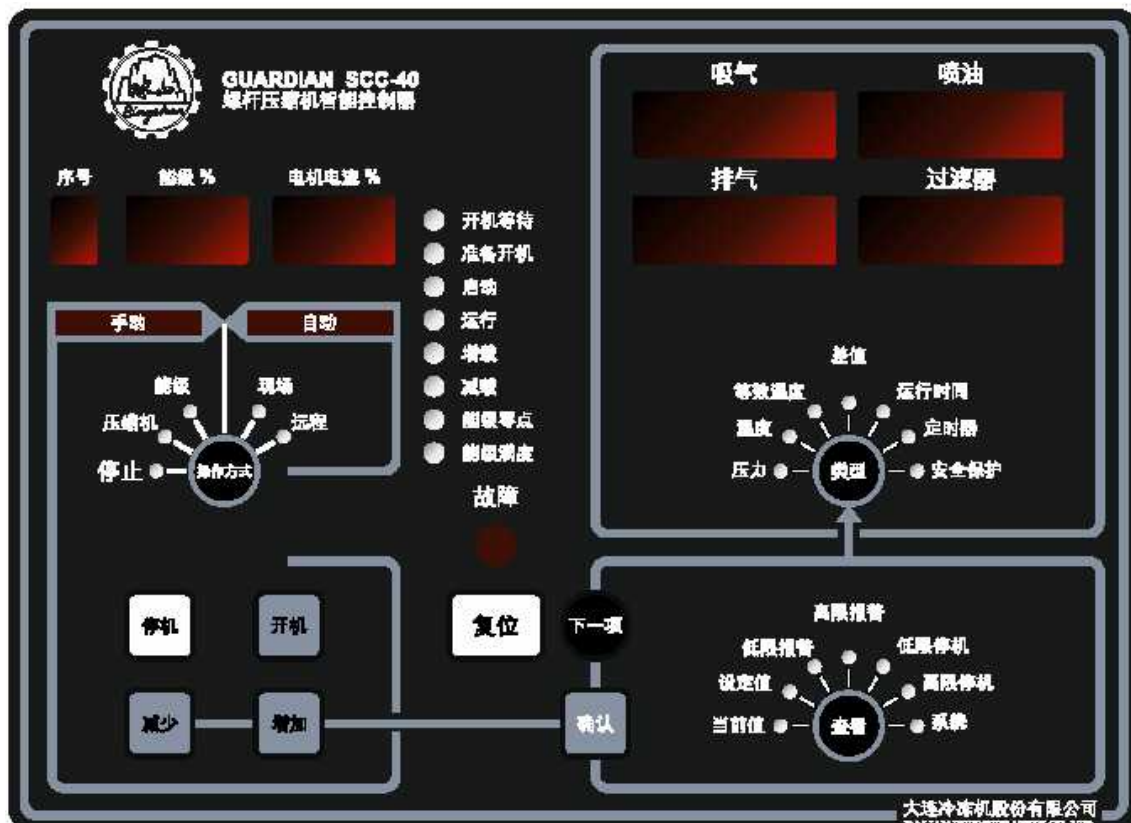



Consultant Mimic Format SCC-50 Standard

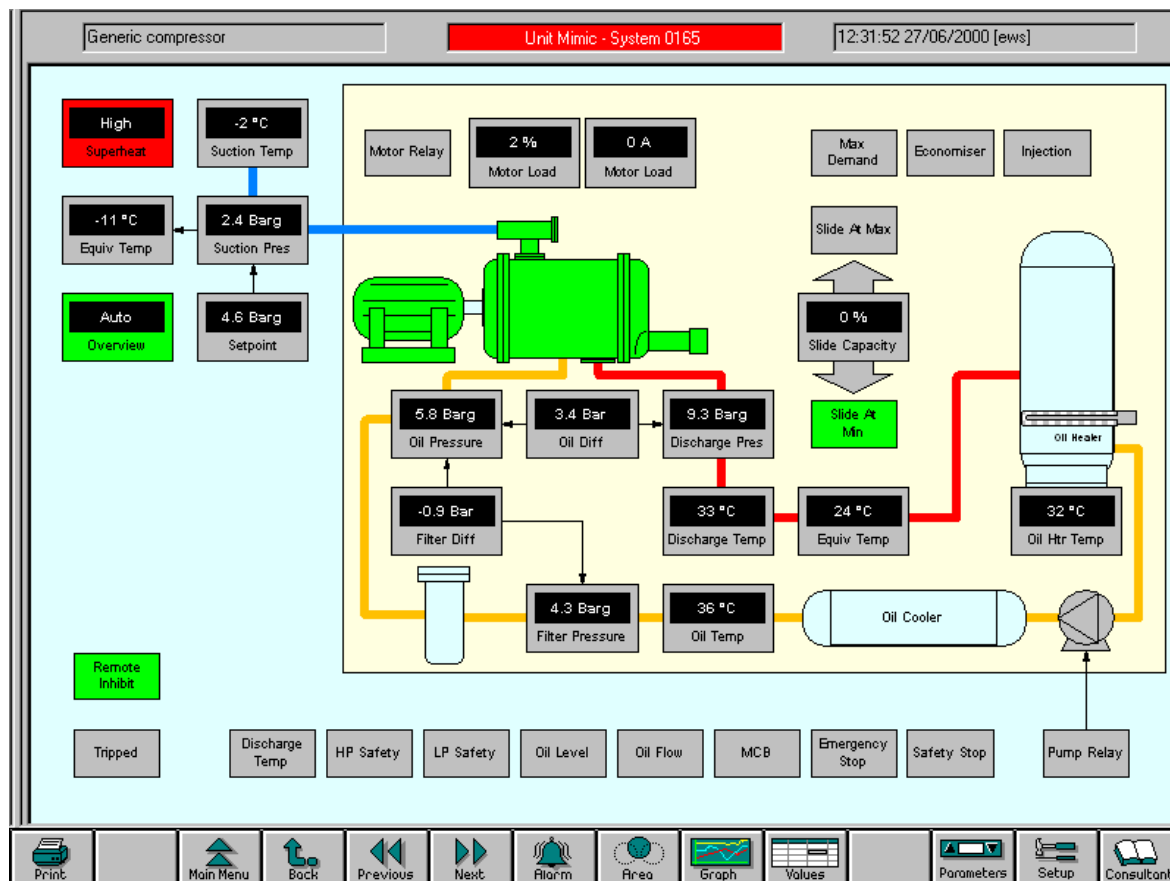

AVAILABLE UNIT MODELS

The Guardian SCC-50 controllers are available in two models, with the following options:

SCC-50 Standard

- 6 pressures
- 6 temperatures
- xx
- 9 output relays
- 4 12V dc inputs
- 4 Mains inputs
- 8 Trips
- 2 Analogue outputs
- 1 Real time clock

xx

SCC-50 Auto VI

- 6 pressures
- 6 temperatures
- 9 output relays
- 4 Stepper Motor Control outputs
- 4 12V dc inputs
- 4 Mains inputs
- 8 Trips
- 2 Analogue outputs
- 1 Real time clock

8-X EXTENSION for REMOTE PUSHBUTTONS

- 8 remote pushbutton inputs.
- local communication with SCC50 via 12C BUS connector.

SCC50 MOTOR TEMPERATURE MONITOR.

- 6 PT100 or PT1000 Temperature inputs
- communication with SCC50 via RS485 control Highway.

SCC controllers powered at 110V ac are available on request but require to be set up prior to delivery.

Guardian SCC50 Product Order Codes		
MG0103	Guardian SCC 50 Standard Screw Comp Controller with AMPS	
MG0104	Guardian SCC 50 AUTO VI Screw Comp Control with AMPS	
MG0101	Guardian SCC 50 Motor Temperature Monitor Extension	
MG0355	Guardian SCC 50 8-X Input Extension	
Transducers		
MT0116	Pres.Trans. 25ba, 4-20ma .	
MT0200	PT1000 Resistance Therm. TI3974	
MT0201	PT1000 100mm Probe Sen-0162c	
MG0126	Stepper motor 7230 R11	

SCC-50 Input/Output Signals

Analogue inputs				
An IP12	A1	Suction pressure	4 to 20mA	-1 to 24 bar g
An IP 11	A2	Discharge pressure	4 to 20mA	-1 to 24 bar g
An IP 10	A3	Oil pressure	4 to 20mA	-1 to 24 bar g
An IP 9	A4	Filter pressure	4 to 20mA	-1 to 24 bar g
An IP 8	A11	Remote pressure control or vibration input	4-20mA 4-20mA	-1 to 24 bar g 0 to 100%
An IP 7		future	4 to 20mA	-1 to 24 bar g
An IP 4	A5	Suction temperature	PT1000	-50 to 125°C
An IP 3	A6	Discharge temperature	PT1000	-50 to 125°C
An IP 2	A7	Oil separator temperature	PT1000	-50 to 125°C
An IP 1	A8	Oil heater temperature	PT1000	-50 to 125°C
An IP 5		Chiller temperature	PT1000	-50 to 125°C
An IP6		Future	PT1000	-50 to 125°C
An IP 9	A9	Slide position potentiometer	0 to 10Vdc	0 to 125%
An IP 16		Slide position using Howden SPI (4-20ma)	4-20ma	0 to 125%
An IP 10	A10	Load current from AMPS Transducer	0 to 10Vdc	0 to 125%
An IP 15		Load current from xxx: 5A CT	0 to 5 AMP ac	0 to 125%
Digital inputs				
Trip 1		Discharge temperature high	dt-H	
Trip 2		L.P. cutout	L.P.	
Trip 3		H.P. cutout	H.P.	
Trip 4		Oil level	LEuL	
Trip 5		Oil diff/ flow switch	FLO	
Trip 6		motor circuit breaker	nncb	
Trip 7		Emergency stop	StoP	
Trip 8		Safety (motor thermistor)	SFTY	
12/24V dc inputs				
Input A		Slide at 50%/ max demand unload		
Input B		Optional keyswitch		
Input C		Slide at minimum 0%		
Input D		Slide at maximum 100%		
Mains inputs				
Input E		Oil pump running		
Input F		Compressor running		
Input G		Refrigeration (inhibit if Rneg)		
Input H		High setpoint/start		
Input I		External RESET pushbutton		
Relay outputs				
R1		Pump motor running	3 Amp inductive 110/240V ac with suppressers	
R2		Compressor motor		
R3		Slide valve load		
R4		Slide valve unload		
R5		Economiser		
R6		Liquid injection		
R7		Oil heater		
R8		Injection 2 or Fans-1		
R9		bypass valve or Fans-2		
RA		Alarm c/o contacts	Not suppressed ; if external relay fit suppressers	
RB		Compressor Trip c/o contacts	Not suppressed	
Analog outputs				
An OP1		Capacity control by variable speed motor	0 to 5V dc	
An OP2		Motor control speed		
Low power digit outputs				
Dig OP C		Not used		12vdc
Dig OP D		Auto VI Stepper Motor PHASE 1		12vdc
Dig OP E		Auto VI Stepper Motor PHASE 2		12vdc
Dig OP F		Auto VI Stepper Motor PHASE 3		12vdc
Dig OP G		Auto VI Stepper Motor PHASE 4		12vdc

Calculated inputs			
A17	Suction equivalent temperature	A1(R22/NH3)	-50 to 100°C
A18	Discharge equivalent temperature	A2(R22/NH3)	-50 to 100°C
A19	Suction superheat	A17-A5	
A20	Discharge diff pressure	A2-A1	-1 to 24 bar g
A21	Oil diff pressure	A3-A2	-1 to 24 bar g
	P_st/no_P/Filt syphen system	A3-A1	
A22	Filter differential pressure, Filter After Pump Filter differential pressure, Filter Before Pump	A4-A3 A2-A4	-1 to 24 bar g
A23	Compressor hours run		0 to 65000 hrs

SCC50 Fuse Ratings

FUSE	Rating	Littlefuse part	CCT protection	Terminal s
F101	125 mA	0453 .125	Com 2 RS485 B line	TB11-2
F102	125 mA	0453 .125	Com 2 RS485 A line	TB11-3
F103	125 mA	0453 .125	Com 1 RS485 B line	TB4-2
F104	125 mA	0453 .125	Com 1 RS485 A line	TB4-3
F105	1 A - T	0454 001.	Display	CN1
F106	1 A - T	0454 001.	Extension	CN2
F201	1 A - T	0454 001.	24 Vdc supply	TB12A-1
F202	1 A - T	0454 001.	12 Vdc supply	TB12-4
F203	125 mA	0453 .125	24 Vdc supply	TB5-2
F204	3.5 A - T	0454 03.5	24 Vac Incoming	TB3-1
F401	125 mA	0453 .125	24 Vdc supply	TB10A-4 TB10-4 TB6-16 TB6-12 TB6-8 TB6-4 TB7A-5
F402	125 mA	0453 .125	5 Vdc supply	TB7-5

SCC50 FUSES and LED LAYOUT

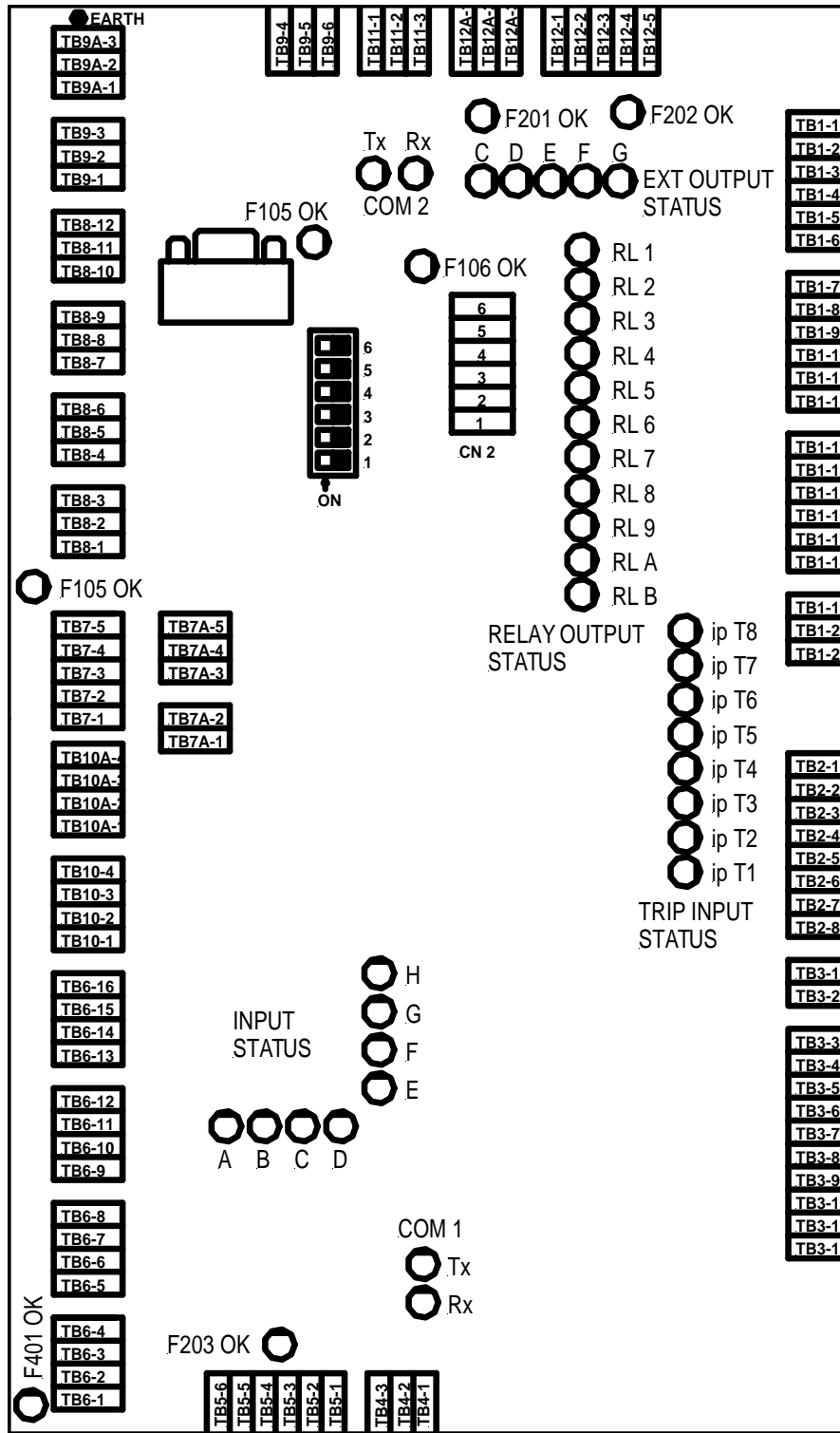

SCC-50 Termination Wiring -

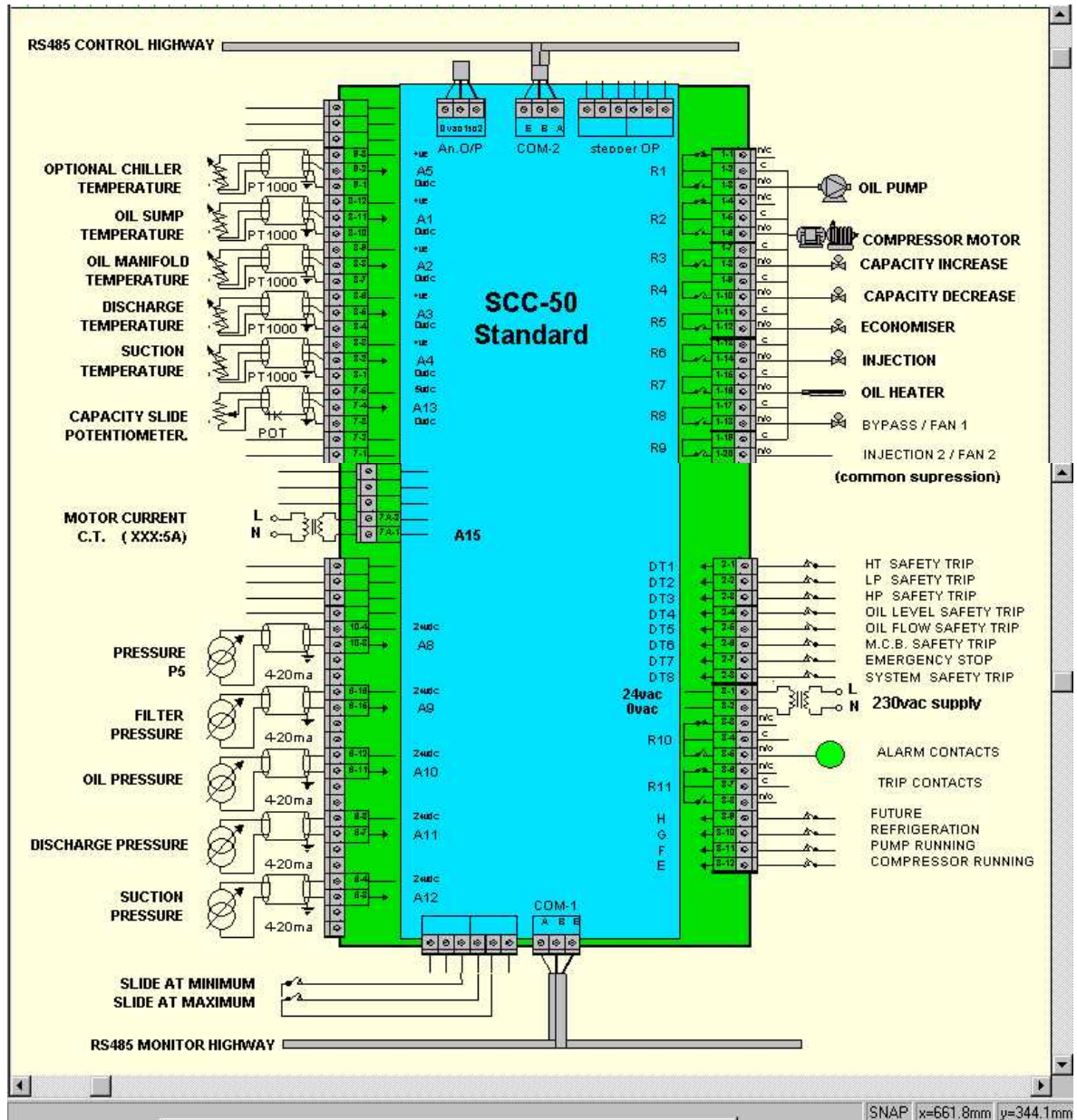

Old Model SCC-40 Termination Wiring -

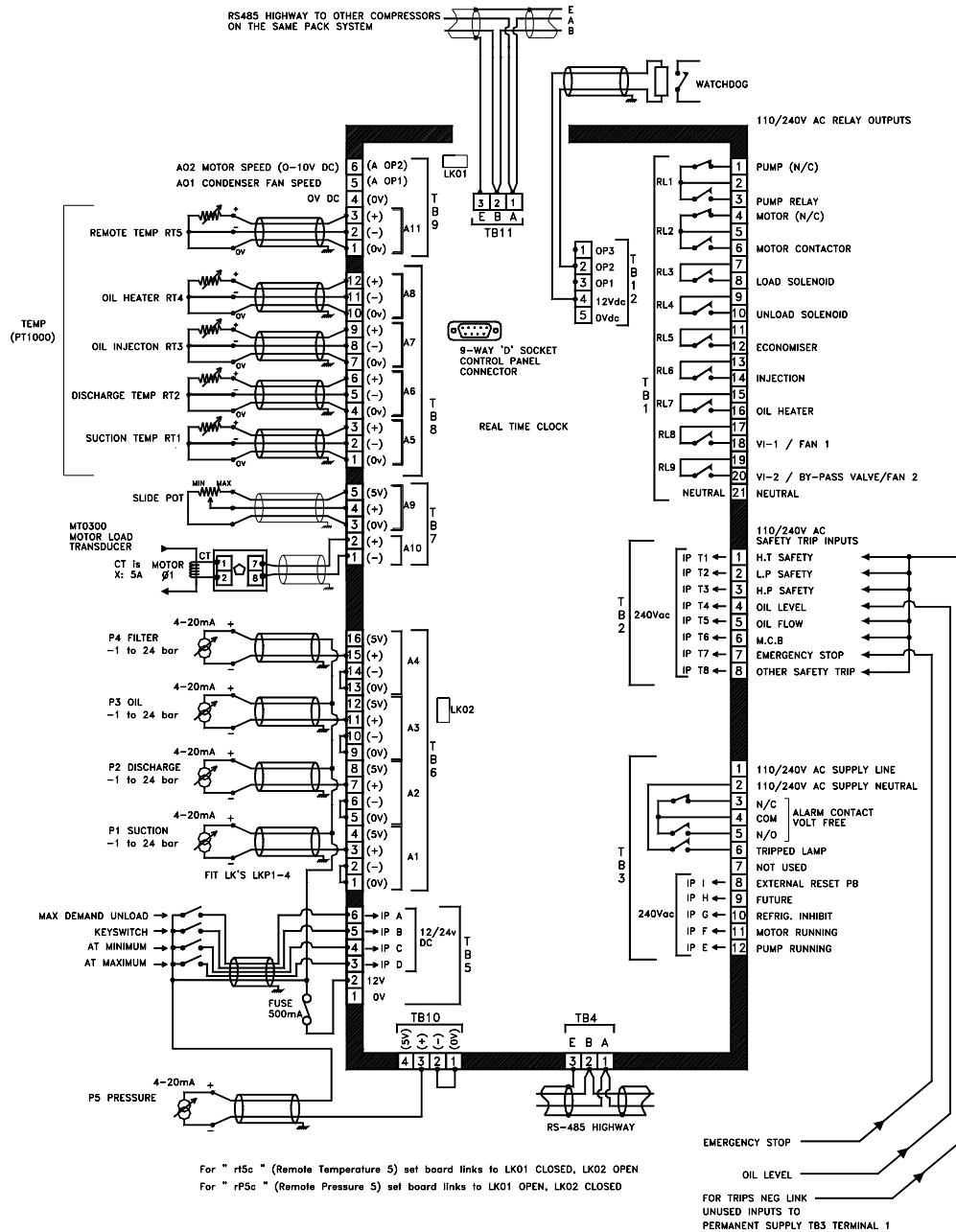

N.B. The Compressor Run Signal (TB3 Terminal 11) must be supplied to the Controller from the Delta Contactor of a Star-Delta System, or the Top of Ramp of a Soft Start System.

XXX ...XXX

SCC50-Auto VI Stepper Motor wiring

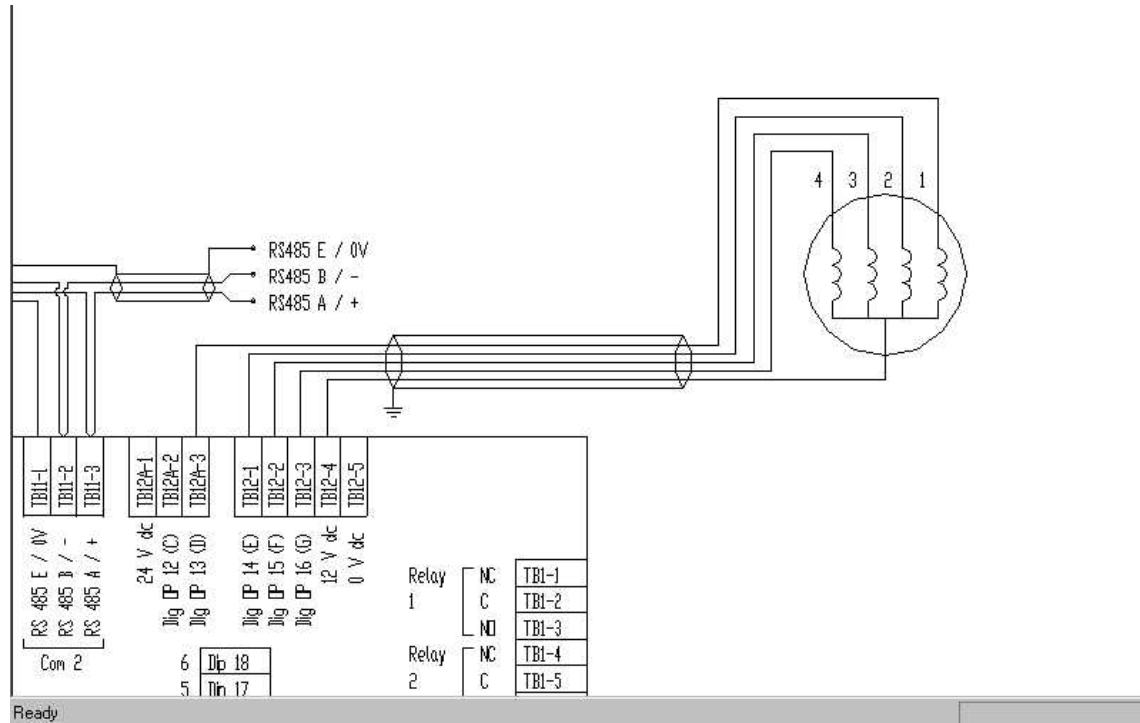

SCC50 8-X Extension - Terminal Connections for Hazardous Area Panel.

Dimensions
70mm x 100mm x 110mm

6-way Cable to SCC50 Connector **CN2**
Clock,data,5vdc,0vdc,2 spare

ALL inputs are now 24Vac/dc

	Neutral (0v)	1	MG0355 8-X Extension Unit (24vac) I²C Add =7	11
DI 1	External OFF(lockoff) Switch	2		12
DI 2	External MANUAL operation Switch	3		13
DI 3	External NORMAL operation Switch	4		14
DI 4	External Stop Compressor button	5		15
DI 5	External Start Compressor button	6		16
DI 6	External Lower Capacity button	7		17
DI 7	External Raise Capacity button	8		18
DI 8	spare	9		19
	Not available	10		20

SCC-50 Motor Monitor Temperature Signals

Analogue inputs			type	SWITCH	range		0vdc	signal	5vdc
An IP 4	T1	Motor Winding temperature 1	PT100	SW1-1=1	-50 to 125°C	TB7	3	4	5
An IP 3	T2	Motor Winding temperature 2	PT100	SW1-2=1	-50 to 125°C	TB8	1	2	3
An IP 2	T3	Motor Winding temperature 3	PT100	SW1-3=1	-50 to 125°C	TB8	4	5	6
An IP 1	T4	Temperature T4	PT1000	SW1-4=0	-50 to 125°C	TB8	7	8	9
An IP 5	T5	Temperature T5	PT1000	SW1-5=0	-50 to 125°C	TB8	10	11	12
An IP6	T6	Temperature T6	PT1000	SW1-6=0	-50 to 125°C	TB9A	1	2	3

SCC-50 Motor Monitor Temperature Wiring

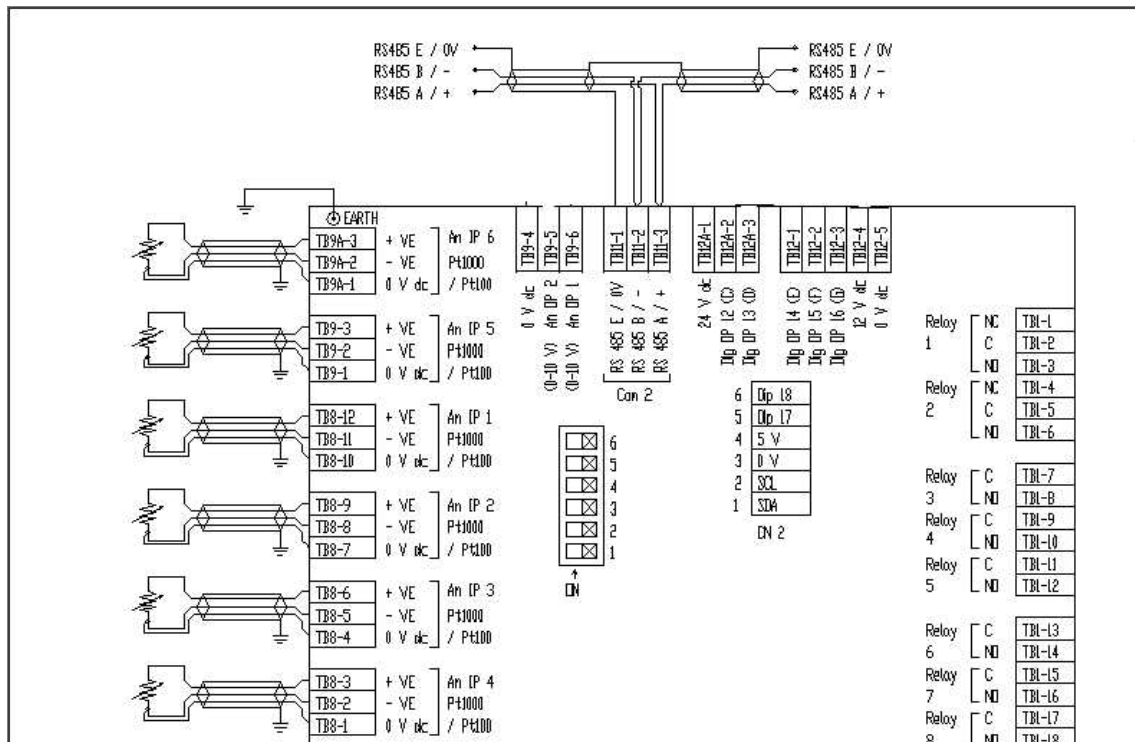

OPERATION

SCC40 PANEL LAYOUT

GUARDIAN SCC40 control panel comprises a membrane pushbutton and display panel mounted on the front of the control unit.

The membrane front panel (shown below) has a black background with white lettering and green buttons with dimensions 300 x 200mm and houses:-

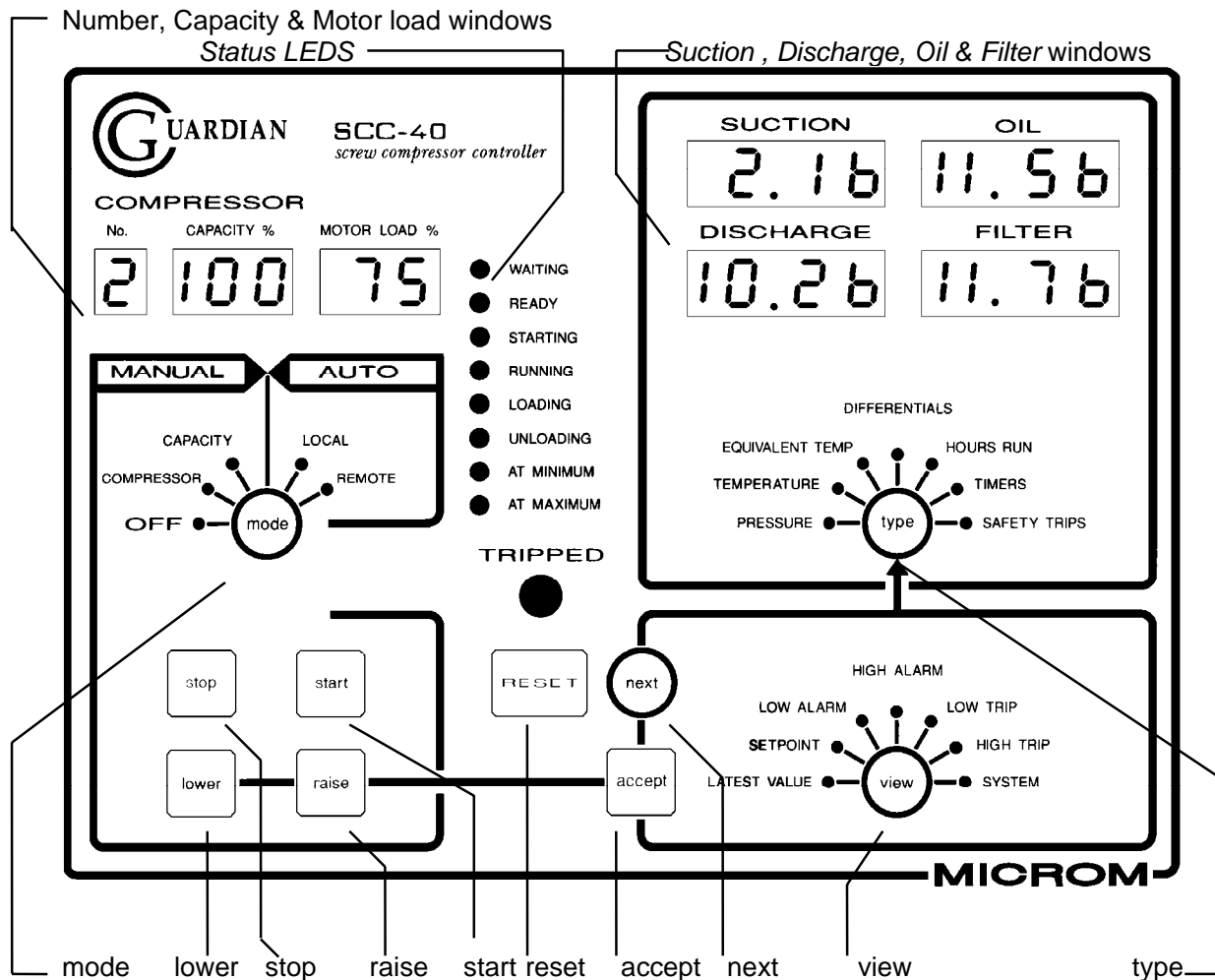

CONTROL STATUS LED LAMPS

WAITING

The compressor is stopped and is waiting timeout of time-between-starts delay or time-after-stop delay or the oil sump temperature is LOW or the discharge temperature is HIGH or the external refrigeration inhibit signal is present in 'AUTOMATIC' mode.

READY

The compressor is stopped and ready to start and has not been tripped. This state is displayed after the compressor has stopped after reaching low-trip suction limit which is considered as a stop and resets automatically.

STARTING

The compressor is running and has received oil pump and compressor running signals but may have other alarms which require action.

RUNNING

The compressor is running and has received oil pump and compressor running signals but may have other alarms which require action.

LOADING

The solenoid loading valve is being pulsed opened to increase the slide capacity.

UNLOADING

The solenoid unloading valve is being pulsed opened to decrease the slide capacity.

AT MINIMUM

The slide is below minimum value (25%) or the external minimum setting limit switch is closed.

AT MAXIMUM

The slide is above maximum value (95%) or the external maximum setting limit switch is closed.

This lamp is lit when 'back-off' unloading is in progress due to over-current, discharge pressure or capacity .

LED LAMPS.

Compressor control status	Used to display compressor control status
TRIPPED	Flashing RED compressor tripped indicator
MANUAL	Mode selections: OFF, COMPRESSOR, CAPACITY
AUTOMATIC	Mode selections: LOCAL, REMOTE
'type'	7 led lamps. Selection for 4-digit LED displays PRESSURE, TEMPERATURE, EQUIVALENT TEMPERATURE DIFFERENTIALS, HOURS RUN, TIMERS & SAFETY TRIPS
'view'	7 led lamps. Selection for 4-digit LED displays LATEST VALUE, SETPOINT, LOW ALARM, HIGH ALARM, LOW TRIP, HIGH TRIP & SYSTEM

SYSTEM STATUS DISPLAYS

System status and set-up data may be displayed by selecting the following;

Press “type” until “**SAFETY TRIPS**” is selected.

Press “view” until “**SYSTEM**” is selected.

The data is displayed in the in the *SUCTION*, *DISCHARGE*, *OIL* and *FILTER* windows by pressing “next.” Only displayed if keyswitch ON, or passcode = 3

Enter System Setup Mode

SUCTION	OIL
	

DISCHARGE	FILTER
	

Press “accept” to enter system set-up mode

Terminate passcode operation.

SUCTION	OIL
	

DISCHARGE	FILTER
	

Press “accept” to remove passcode

Control status displays.

SUCTION	OIL			
Cont	rol			
DISCHARGE	FILTER			
9999	9999			
	YYYY=			
DISCHARGE	FILTER			
Suact	ron			Remote master suction control.
DISCHARGE	FILTER			
FULL	LOAD			Remote but at maximum load.
DISCHARGE	FILTER			
SLI	de			Remote slave in load sharing.
DISCHARGE	FILTER			
StAn	dbY			Remote mode stopped but ready.
DISCHARGE	FILTER			
LOC	AL			Compressor in local mode
DISCHARGE	FILTER			
Inh	blE			Local mode but inhibited.
DISCHARGE	FILTER			
MAN	UAL			Compressor in manual.
DISCHARGE	FILTER			
----	OFF			Compressor OFF.

Relay output status.

SUCTION	OIL		
00E	PUES		
DISCHARGE	FILTER		
PCEL	HRLE		

- Is displayed if relay is OFF
- P** Pump motor ON
- C** Compressor motor ON
- E** Economiser ON
- L** Liquid injection
- H** Oil heater ON
- r** Slide valve LOAD
- L** Slide valve UNLOAD
- E** Tripped relay ON

Inputs

SUCTION	OIL		
1nP	UES		
DISCHARGE	FILTER		
Abcd	EF9H	A	Maximum demand input (SCC25 Slide at 50%)
		b	Optional keyswitch (access code override)
		c	Slide at minimum 0%
		d	Slide at maximum 100%
		E	Oil pump running
		F	Compressor running
		g	Refrigeration inhibit
		H	Spare
		I	External reset pushbutton

8-X Inputs

1nP	UESE		
DISCHARGE	FILTER		
Abcd	EF9H	A	External OFF(lockoff) Switch
		b	External MANUAL operation Switch
		c	External NORMAL operation Switch
		d	External Stop Compressor button
		E	External Start Compressor button
		F	External Lower Capacity button
		g	External Raise Capacity button
		H	spare

Trip inputs.

SUCTION	OIL	
67	PS	
DISCHARGE	FILTER	
1234	5678	
		- Is displayed if trip input is OFF
		1 Discharge temperature high
		2 L.P. cutout
		3 H.P. cutout
		4 Oil level
		5 Oil flow switch
		6 Motor circuit breaker
		7 Emergency stop
		8 Safety (motor thermistor)/Flow switch 2

Analog output voltages..

SUCTION	OIL	
801	802	
DISCHARGE	FILTER	
10.00	00.00	Output in volts

SAFETY TRIP INDICATIONS

When detected, the following safety trips alternate the trip messages below with 'TRIP' in the windows specified and flash the 'type' = SAFETY TRIPS LED lamp. Accept and reset procedures are the same as for other trips. The messages depend on the model configuration

Trip	Model SCC50	message	flash	window
T1	Discharge temp hi trip	DE-H	Trip	FILTER
T2	L.P. cutout	L.P.	Trip	SUCTION
T3	H.P. cutout	H.P.	Trip	DISCHARGE
T4	oil flow switch	FL01	Trip	FILTER
T5	oil level	LE01	Trip	OIL
T6	motor circuit breaker	MCB	Trip	SUCTION
T7	emergency stop	SEOP	Trip	DISCHARGE
T8	safety trip (other) Flow switch 2.	SE04 FL02	Trip	OIL

STARTING and RUNNING Timeout Trips

When detected, the following timeout trips alternate the trip messages below with 'TRIP' in the windows specified and flash the 'type' = TIMERS LED lamp.

Compressor motor running signal off.	MCOT	Trip	SUCTION
slide not at minimum	S-UP	Trip	DISCHARGE
pump running signal off	POPP	Trip	OIL

Accept and reset procedures are the same as for other trips.

DISPLAY PUSHBUTTON OPERATION

Display of all compressor measured values, setpoints, alarm and trip limit settings is performed by repeated pressing of either the **'view'** and / or **'type'** pushbuttons.

At each button press the associated selection LED lamp advances by one in a clockwise direction indicating the type or setting of the value displayed in the; **SUCTION, DISCHARGE, OIL, FILTER, CAPACITY%** and **LOAD%** windows.







'view'





To display the latest temperature values, the **'view'** pushbutton is pressed repeatedly until the **LATEST VALUE** LED lamp is lit.

'type'

The **'type'** pushbutton is then pressed repeatedly until the **TEMPERATURE** LED lamp is lit.







The **SUCTION, DISCHARGE, and OIL** windows now display the latest measured values of suction, discharge and oil temperatures respectively.





“   view ” = “LATEST VALUE”
“   type ” = “TEMPERATURE”

SUCTION	OIL
	
DISCHARGE	FILTER
	

To display the high alarm settings for pressures, the **'view'** pushbutton is pressed repeatedly until the **HIGH ALARM** LED lamp is lit, and then the **'type'** pushbutton is pressed repeatedly until the **PRESSURE LED** lamp is lit.

The **SUCTION, DISCHARGE, OIL** and **FILTER** windows now display the high alarm limit settings, if applicable, for suction, discharge, oil and filter pressures respectively.

“   view ” = “HIGH ALARM”
“   type ” = “PRESSURE”

SUCTION	OIL
	
DISCHARGE	FILTER
	

All pressures are displayed in the range: -1.0b to 24.0b where b= bar gauge

All temperatures are displayed in the range -50C to 125C where C= degrees centigrade



LOAD% and CAPACITY% are displayed in the range 0% to 125% where % is of maximum scale.



Compressor **HOURS RUN** is displayed using the SUCTION and OIL windows from 0 to 65000 in the form

SUCTION	OIL
■■■65	000H
DISCHARGE	FILTER
■■■■	■■■■
DISCHARGE	FILTER
L A S T	2359

Last trip time alternates with trip after any trip fail.

TIMERS setpoints for stage-up and stage-down, oil diff are displayed in minutes

“   view” = “SETPOINT”

“   type” = “TIMERS”

SUCTION	OIL
3.50	2.3P
DISCHARGE	FILTER
2.0d	0.0o

u = stage-up = 3.5 mins
P = prelube delay = 2.3 mins

d = stage-down = 2.0 mins
o = pump off delay = 1.5 mins

If no buttons have been pressed for 5 minutes, the SUCTION, DISCHARGE, OIL and FILTER windows revert to the default display of latest pressure values with;

'view' = LATEST VALUE,
'type' = PRESSURE

CONTROL PUSHBUTTON OPERATION

“mode”

mode may be pressed at any time to change the operating mode of the compressor from **'MANUAL'** to **'AUTOMATIC'** control and visa versa. At each button press the associated 'mode' selection LED lamp advances by one in a clockwise direction indicating the required new mode selection.

Note: Compressor Mode changes only take place when the mode selection has been unchanged for 5 seconds.

“Mode-MANUAL”

With the **'OFF'** LED lamp selected in **MANUAL** mode, the compressor is automatically stopped if running lamp is lit and subsequently ignores any further manual or automatic control requests.

With the **'COMPRESSOR'** LED selected in **MANUAL** mode, the compressor may be started and stopped by operator pushbutton control using **'start'** and **'stop'**.

With the **'CAPACITY'** LED selected in **MANUAL** mode, the compressor capacity may be changed by operator pushbutton control using **'raise'** and **'lower'** buttons, provided the compressor is running.

“Mode-AUTOMATIC”

In **LOCAL** automatic mode, the compressor is started and stopped under control of the suction pressure setpoint and an optional external refrigeration allow/inhibit signal. Operation in this mode is independent of any other compressors in the system.

REMOTE automatic mode allows up to eight SCC-50 units to be connected via a two-wire communication link to provide 8-compressor system control. Any change to REMOTE mode whilst the compressor is running causes the compressor to automatically load up to 100% or assume suction pressure control if it is the only one in remote mode.

“RESET”

RESET is used to reset all control sequences prior to restarting the compressor after a **'TRIPPED'** condition has occurred and subsequently been corrected. When pressed with the **'TRIPPED'** LED lamp either flashing or steady the TRIPPED lamp is switched off, any flashing **'type'** alarm selection LED lamp goes steady, all display measurement values are unfrozen from the pre-trip conditions and revert to latest values and either **'WAITING'** or **'READY'** compressor control status LED lamps are lit.

“Call Frig Engineer”

The RESET pushbutton is inhibited if more than 6 trips occur within a 24 hour period and the following message is displayed.

SUCTION	OIL
CALL	FRIG
DISCHARGE	FILTER
ENG	REEF

RESET is enabled and message is removed by keyswitch operation or entry of passcode level 3.

“stop”

'stop' may be pressed at any time in either 'MANUAL' or 'AUTOMATIC' mode and, if the compressor is running, causes the compressor to shutdown and stop in an orderly manner.

The stop sequence lowers the slide to minimum, selects minimum VI setting, stops the compressor, extinguishes the 'RUNNING' LED lamp, starts the delay_after_stop timer, lights the 'WAITING' LED lamp, continues to lower the slide until 'at_minimum' and then stops the oil pump after the pump_stop time.

“start”

start only operates in 'MANUAL' mode with the 'COMPRESSOR' LED lamp selected, the compressor 'READY' LED lamp on. The starting sequence lights the 'STARTING' LED lamp, starts and checks the oil pump, lowers the slide to minimum, selects minimum VI setting, starts and checks the compressor, starts the time_between_starts timer and then automatically raises the slide to 25% capacity.

When the compressor is running at above 25% capacity the 'STARTING' LED lamp is replaced by the 'RUNNING' LED lamp.

“Lower”

lower may be used in 'MANUAL' mode with the 'CAPACITY' LED lamp selected, the compressor 'RUNNING' LED lamp on. Whilst 'lower' is being pressed, the slide unloading solenoid valve and the 'UNLOADING' LED lamp are pulsed for the preset lower_pulse_time every five seconds to decrease the compressor capacity as required

The 'lower' pushbutton is also used after 'next' has been pressed to decrease the displayed values of setpoints, high, low, alarm and trip settings prior to changing them using 'accept'.

“Raise”

raise may be used in 'MANUAL' mode with the 'CAPACITY' LED lamp selected, the compressor 'RUNNING' LED lamp on and the 'TRIPPED' LED lamp off. Whilst 'raise' is being pressed, the slide loading solenoid valve and the 'LOADING' LED lamp are pulsed for the preset raise_pulse_time every five seconds to increase the compressor capacity as required.

The 'raise' pushbutton is also used after 'next' has been pressed to increase the displayed values of setpoints, high, low, alarm and trip settings prior to changing them using 'accept'.

SETTINGS CHANGE PUSHBUTTON OPERATION

“next”

'next' is used to initiate **'settings change'** operation provided an external security key or ink is activated or the appropriate passcode has been entered.
(See configure unit model section)
Passcode entries remain valid for 30 minutes.

Subsequent pressing of the **'next'** pushbutton cycles through the seven display windows flashing the last digit of each in turn to indicate which window is selected for changes. Unused windows are skipped.
Different settings may be displayed using **'view'** and **'type'** selections.
Changes are made by using the **'raise'** and **'lower'** pushbuttons to alter the displayed setting which then must be followed by pressing the 'accept' pushbutton.

“Accept”

'accept' pushbutton enters new values of setpoints, timers, alarm or trip settings.

“raise”

If the 'raise' pushbutton is held on for more than 2 seconds then the value increases automatically at a higher rate.

“Lower”

If the 'lower' pushbutton is held on for more than 2 seconds then the value decreases automatically at a higher rate.

If an attempt is made to change a setting using the incorrect passcode then the display defaults to:-

'view' = LATEST VALUE

'type' = PRESSURE

“RESET”

Exits setup mode without clearing passcode pressing 'next' again will flash value to be changed.

ALARM ACCEPT AND RESET PUSHBUTTON OPERATION

The “**accept**” pushbutton is used to acknowledge a high, low, alarm or trip condition. It stops the flashing of the '**type**' LED selection and the '**TRIPPED**' LED lamp thus allowing other '**view**' or '**type**' selections to be made in order to investigate the fault.

The '**TRIPPED**' LED lamp remains on until '**RESET**' is pressed.
After an alarm, '**view**' and '**type**' selections are inhibited until 'accept' is pressed.

ALARM and TRIP INDICATIONS

The high and low alarm and trip conditions listed below are detected and displayed in all control modes.

New alarms or trips automatically select '**view**' = LATEST VALUE and flash the appropriate '**type**' LED lamp for the alarm or trip point
ie (PRESSURE, TEMPERATURE, DIFFERENTIAL)

The window displaying the alarm point alternates the latest value with a '**trip**', '**Hi**' or '**Lo**' fail message.

The '**TRIPPED**' LED flashes for all trips and the latest values are frozen at the time of the trip for subsequent fault diagnosis.

When '**accept**' is pressed the '**type**' LED stops flashing and other display selections may be viewed if required.

The alarm value continues to alternate with '**Hi**' or '**Lo**' whilst an alarm is present.

The tripped value continues to alternate with '**trip**' until '**RESET**' is pressed.

Value	Description	Window	'type'	'view' selection			
				Lo-alarm	hi-alarm	low trip	high trip
1	suction press	SUCTION	PRESS	stop		yes	
2	discharge press	DISCHARGE	PRESS		start-unload		yes
3	oil pressure	OIL	PRESS				
4	filter pressure	FILTER	PRESS				
5	suction temp	SUCTION	TEMP		yes		yes
6	discharge temp	DISCHARGE	TEMP		yes		yes
7	oil temp	OIL	TEMP		yes		yes
8	oil temp (sump)	OIL	TEMP	heater			
9	slide %	CAPACITY	PRESS	yes	stop-load		
10	motor load %	LOAD%	PRESS		start-unload		
Calc							
17	equiv-suct-temp	SUCTION superheat	EQIV.				
18	equiv-disc-temp	DISCHARGE superheat	EQIV.				
19	suct-superheat	SUCTION	DIFF	yes	yes	yes	yes
21	diff-disc-pressure	DISCHARGE	DIFF				
22	diff-oil-pressure	OIL	DIFF	yes		yes	
23	diff-filter-pressure	FILTER	DIFF		yes		yes

SETPOINTS

SUCTION PRESSURE SETPOINT CONTROL. -0.5 to 5.0bar

the suction pressure control setpoint for the compressor in increments of 0.1 bar. If 'CHIL' is selected then loading is inhibited until the suction is above this setpoint.

EQUIVALENT TEMPERATURE SETPOINT (tcon) -50 to 50°C

the equivalent temperature control setpoint of the compressor in increments of 1°C. This setpoint can be switched between two values using input H (high setpoint if on).

WATER CHILLER TEMPERATURE SETPOINT (CHIL) -1 to 24°C

the water chiller temperature RT5 control setpoint of the compressor in increments of 0.1°C.

SETPOINT CONTROL

Capacity loading takes place when the control temperature or suction pressure is greater than the setpoint.

Capacity unloading takes place when the temperature or suction pressure is less than the setpoint.

When the suction pressure is (0.3 bar, 0.3°C, 3°C) above or below the setpoint then the width of the load and unload pulses is automatically doubled and pulses are sent every five seconds to achieve suction setpoint more rapidly.

When the setpoint is within 0.3 of the setpoint then the loading valves are pulsed at the variable CAPACITY LOAD DELAY period to give time for plant to respond before sending the next pulse which prevents 'hunting'.

When the slide capacity is below 75%, loading pulses are doubled to counteract the effect of a non linear slide travel.

DISCHARGE TEMPERATURE SETPOINT

Liquid Injection ON. setpoint is the discharge temperature above which the liquid injection valve is opened. The liquid injection valve is shut when the temperature falls 5 degrees C below this setpoint.

Filter differential high alarms are inhibited until this setpoint is reached in order to ensure reasonable oil flow.

LIQUID INJECTION 2 IF 'Bypass' valve is selected then a second injection valve connected to R8 output is switched on 5°C above the discharge temperature setpoint and switched off at the setpoint

DISCHARGE DIFFERENTIAL SETPOINT STOP PUMP

When '**P-St**' is selected, this is the differential discharge to suction pressure above which the pump is stopped if it is only required during compressor startup.

**LOAD% PRESSURE SETPOINT
STOP-LOAD**

The % load current above which no further loading pulses are allowed

CAPACITY % PRESSURE HIGH ALARM

The maximum slide capacity % above which the compressor inhibits loading pulses.

**LOAD % PRESSURE HIGH ALARM
START-UNLOAD**

The % load current High Alarm Limit above which capacity unloading pulses are automatically started.

**DISCHARGE PRESSURE HIGH ALARM
START-UNLOAD**

The discharge pressure High Alarm Limit above which capacity unloading pulses are automatically started.

**CAPACITY % PRESSURE SETPOINT
ECONOMISER ON.**

The slide position above which the economiser is switched on when the motor is running and 'back-off' is not in progress.
The economiser is switched OFF when the slide is 5% below this setpoint.
The economiser is also switched off if 'Back-off' unloading occurs due to over-current or high discharge pressure. After back-off, the economiser time delay 'ETxx' minutes must elapse before the economiser can be switched on again.

**FILTER TEMPERATURE SETPOINT
OIL HEATER OFF**

Oil heater off setpoint is the oil sump temperature above which the oil heater is switched OFF. The oil heater is switched ON when the temperature falls below this setpoint provided the compressor is not 'running'.

**FILTER TEMPERATURE LOW ALARM
OIL HEATER ON = PUMP INHIBIT**

The oil sump temperature below which the oil heater is switched on and the pump is not allowed to start. The oil heater is switched off when the oil sump temperature is 5°C above this limit if this is higher than the control setpoint above.

**DISCHARGE TEMPERATURE HIGH ALARM
=MOTOR-START-INHIBIT**

The discharge temperature above which the pump is not allowed to start.

**CAPACITY PRESSURE LOW ALARM
=MIN LOAD %**

The minimum slide % at which a Load sharing compressor is allowed before it automatically stops after the stage-down time.

**CAPACITY PRESSURE LOW TRIP
=COMPRESSOR AUTO STOP**

The % Slide position at which below setpoint the stagedown timer autostops the compressor, restart is automatic after starts per hour **SH** timed out.
No Action If Set to Zero

**SUCTION PRESSURE LOW ALARM/LOW TRIP
=STOP-COMPRESSOR**

The minimum suction pressure for the compressor in increments of 0.1 bar.
This setpoint merely stops the compressor which automatically restarts again when the suction pressure rises again without needing RESET to be pressed.

**DISCHARGE PRESSURE SETPOINT
CONDENSER FANS 1 & 2**

With R8,R9 relays selected for 'FANS' FAN-1 (R8) is switched on when the discharge pressure is above this setpoint. FAN-2 (R9) is switched on '**Ft0.x**' bar above this setpoint. Both fans are switched off 0.5 bar below their respective setpoints.

CONTROL MODES

GENERAL

The controller is a general purpose screw compressor controller. It may be used as a stand-alone unit or may be integrated into an overall pack control strategy via the communications link with upto 7 other units.

The control and monitoring operations are based on the inputs and outputs described previously.

The controller has three modes of operation:-

i) MANUAL

Operator required to start/stop and control capacity.

ii) LOCAL AUTOMATIC

Compressor start/stops and controls capacity on suction pressure, equivalent temperature or chiller temperature setpoint control provided refrigeration input signal is enabled.

iii) REMOTE AUTOMATIC

Uses communications link to establish the most efficient loading of up to eight compressors on the same suction line.

Multi-compressor loading can be selected to give priority in different ways:-

a) runH uses Hours run on each compressor to determine which is best

compressor to start or stop. The compressor with the least run hours is best to start, the compressor with the most runhours is best to stop.

- b) LEAD Always start this compressor first and stop it last
- c) LAG start this after LEAD compressor at maximum, OFF or tripped.
- d) StBy Only start this compressor if another compressor is tripped.

SCC50 8-X EXTERNAL CONTROL PANEL OPERATION

An external control panel is normally used when flameproof control facilities are required at a compressor in a hazardous area. The external control panel is mounted near the compressor and provides one 3-way switch (OFF, MANUAL, NORMAL) and four pushbuttons (Stop, Start, Lower, Raise). The digital inputs from the switch and buttons on the external panel must be routed to the SCC50 controller via a SCC50 8-X extension unit

The SCC50 controller and the SCC50 8-X Extension unit are usually mounted some distance away in the safe area.

All SCC50 8-X inputs are 24 Vac/dc to allow use of input safety barriers.

The functions of these External Panel control inputs is as follows

<p>External OFF (lockoff) Switch</p>	<p>External OFF <i>This position stops the compressor and totally inhibits further compressor operation</i></p> <p>SCC50 controller forced into OFF mode SCC40 panel red MANUAL LED flashes to show external panel button control. External stop, External start, External Lower Capacity, External Raise Capacity buttons are inoperative SCC40 panel 'mode' button for OFF, Compressor, Capacity, Local, Remote is inoperative SCC40 panel control buttons Stop, Start, raise, lower are inoperative PC Communication for changes to mode and control is inoperative</p>
<p>External MANUAL operation Switch</p>	<p>External MANUAL <i>This position enables compressor operation from the external panel and inhibits control from elsewhere.</i></p> <p>SCC50 controller forced into Compressor Manual mode SCC40 panel red MANUAL LED flashes to show external panel button control. External stop, External start, External Lower Capacity, External Raise Capacity buttons are operative SCC40 panel 'mode' button for OFF, Compressor, Capacity, Local, Remote is inoperative SCC40 panel control buttons Stop, Start, raise, lower are inoperative PC Communication for changes to mode and control is inoperative</p>

<p>External operation Switch NORMAL</p>	<p>External NORMAL <i>This position inhibits compressor operation from external panel and allows operation from SCC40 panel. This position should be selected after completion of control operations at external panel.</i></p> <p>SCC50 controller obeys all normal mode and control selections from SCC40 panel External stop, External start, External Lower Capacity, External Raise Capacity buttons are inoperative SCC40 panel 'mode' button for OFF, Compressor, Capacity, Local, Remote is operative SCC40 panel control buttons Stop, Start, raise, lower are operative PC Communication for changes to mode and control is operative</p>
<p>External Compressor button Stop</p>	<p>IF External MANUAL selected, behaves the same as SCC40 panel 'stop' button. Otherwise inoperative. stops compressor if running.</p>
<p>External Compressor button Start</p>	<p>IF External MANUAL selected, behaves the same as SCC40 panel 'start' button. Otherwise inoperative. starts compressor if ready and stopped.</p>
<p>External Lower Capacity button</p>	<p>IF External MANUAL selected, behaves the same as SCC40 panel 'lower' button. Otherwise inoperative. unloads compressor if running and not 'at min'.</p>
<p>External Raise Capacity button</p>	<p>IF External MANUAL selected, behaves the same as SCC40 panel 'raise' button. Otherwise inoperative. loads compressor if running and not 'at max'.</p>

CONTROL

COMPRESSOR CONTROL OPERATION

POWER UP

After a power up the controller checks the integrity of the parameters it maintains in EEROM memory. If this check fails the controller will go to the OFF MANUAL mode. Otherwise these parameters are used and the controller reverts to its previous mode.

All timers are reset so that the compressor cannot restart until the time after stop timer has elapsed (2 mins). This will give the operator sufficient time to change modes etc. The controller checks for any fault conditions and if any are present it displays the tripped status, otherwise '**WAITING**' status is displayed

READY/WAITING

After a power reset the waiting status is displayed until the time after stop timer has elapsed, and the temperature of the oil is greater than the inhibit start setpoint as set in **Filter Temp Low Alarm**, after which the ready status is displayed.

If an external start/stop refrigeration signal is used then the waiting status is displayed whilst the stop signal is present.

The controller will allow up to 20 starts per hour. It achieves this by maintaining a time between starts timer. This timer is reset each time the compressor is started. If this timer has not elapsed, after the compressor has stopped, then the waiting state will be displayed for the remaining time.

Once the Ready state is indicated the controllers next actions are dependant on the mode selected:-

- i) **MANUAL mode** - Provided COMPRESSOR is selected the controller will respond to START being pressed.
- ii) **LOCAL AUTOMATIC** - The controller looks for the suction pressure to be above the control band or the external refrigeration signal to go to start.
- iii) **REMOTE AUTOMATIC** - In a pack system of upto eight compressors the compressor with the least runtime hours and which is also in the ready state is considered to be the Master. Once the control temperature/suction pressure goes above the control setpoint then the Master compressor will start.

STARTING

After a start request has been made the Oil pump is started. Provided a pump running signal has been received, the oil differential limit is satisfied, (within the oil differential delay time 'dt'), and the slide is at minimum the motor will then start.

If the slide is not at minimum when the pump is started then the following procedure is completed:-

1. The un-load solenoid is energised.
2. If the slide returns to minimum within the differential delay time, 'dt', then motor start will proceed as above.
3. When the slide does not return to minimum within 'dt' the pump continues to run until the slide is at minimum or the pump pre-lube delay is exceeded.
4. If the slide is at minimum then the pump is stopped and a motor re-start delay time is enforced before a normal starting procedure is attempted. This allows excess oil in the compressor to drain away.
5. If the slide has not made minimum after the pre-lube delay the compressor will go to the tripped state '**S-uP'/trip'**.
6. If the pump run signal is not present within 'dt' the compressor goes to the tripped state '**PunP'/trip'**
7. IF 'P-PL' pump pre-lube is selected then the . Pump is run for duration of Pump timer. If the oil diff is satisfied, (diff is oil - suction), Motor is started. Once the motor is in the run state the pump is stopped.
8. If the motor running signal, (motor in delta), is not received within thirty seconds the compressor will go to the tripped state '**nnot'/trip'**.

RUNNING

For all modes of operation status inputs and cutout trip limits are continuously checked for fault conditions. If any are found then the compressor is immediately stopped and the appropriate trip mode indicated. Over current and high discharge temperature capacity unloading operate in all in all modes.

MANUAL MODE.

In MANUAL mode, provided CAPACITY is selected, the capacity may be adjusted by operation of the RAISE/LOWER buttons. A raise/lower request is actioned at one pulse every five seconds, the pulse duration dependant on the RAISE/LOWER pulse width settings.

LOCAL AUTOMATIC.

In LOCAL AUTOMATIC mode the capacity is adjusted dependant on the suction pressure being above or below the control band selected.

REMOTE AUTOMATIC.

In REMOTE AUTOMATIC mode up to six compressors are available to run. One compressor always assumes overall control and is referred to as the Master. The Master compressor is selected on least runtime hours and Ready status. If runtime hours are equal then priority is based on the compressors' unit number, compressor 1 having the highest priority.

When a compressor has established its' self as Master it uses the communications link to request status information from the other compressors. The action of transmitting by the Master will prevent any other REMOTE mode compressors from starting, regardless of suction pressure.

The status request command also contains the status information of all other compressors. This status information consists of:-

- i) Runtime hours
- ii) Slide position
- iii) Compressor mode requires REMOTE automatic for control.
- iv) Compressor State - Ready, Waiting, At minimum, At maximum, Master, Load sharing, Over current, High Discharge.

When the suction pressure is above the control setpoint then the Master compressor will start. It will then attempt to maintain control by automatic adjustment of its capacity. If the suction pressure remains above the control band (+0.1 bar) such that the slide has reached 100% or the compressor has had an over current or high discharge back-off, then the stage up timer will be started. The timer will be reset if the capacity falls below 100% or the suction pressure goes into or below the control band after a back-off.

Once the stage up timer elapses the Master compressor will stop transmitting, releasing control to the compressor with the next highest priority. As all compressors have runtime hours etc., each compressor waits for its priority time out period before becoming Master.

The next compressor to establish its self as Master goes through the starting procedure. Whilst the suction pressure is above the control band the Master continues to raise its slide. When the Master brings the suction pressure into or below the control band; then, provided it slide is less than Capacity Low Limit,

it will optimise capacity to improve efficiency. The Master will select a compressor to balance its slide capacity with. To do this it selects the compressor with the greatest runtime hours, from the compressors that are at Maximum capacity.

The Master then sets the Load sharing status flag of the required compressor. This compressor then goes into slide position regulation mode, selecting a slide capacity setpoint that divides the available capacity between the Master and itself. The load sharing compressor moves to its calculated slide position, from 100%, by pulsing its lower valve. The Master compressor remains in suction pressure regulation mode, so as the pressure goes above the control band it will increase its capacity. The load sharing compressor continues to adjust its slide position setpoint as required.

The following situations may now occur:-

i) The refrigeration demand increases:-

Both compressors reach Maximum capacity and maintain this for the stage up period of the Master. The Master then removes the load sharing status, updates this status change to all other controllers and then stops transmitting so that the compressor with the next highest priority will take over.

ii) The refrigeration demand decreases:-

In this situation the load sharing compressor will not allow its slide to go below 50%. The Master compressor will compensate by continuing to reduce its capacity. When the total load of the 2 compressors is <100% for the stage down period then the load-sharing compressor will remove its load sharing status, ramp its slide down to minimum and then stop.

The master compressor will maintain suction pressure regulation.

iii) Master compressor trips.

If the load sharing compressor is not fully loaded it will be given highest priority, revert to suction pressure regulation mode and become Master.

iv) **Load sharing compressor trips.**

The Master compressor maintains suction pressure regulation and if the previously stated conditions occur it will look for another compressor to load share with.

Any mode changes made to the Master or load sharing compressor then the response is the same as for a trip condition.

STOPPING

The compressor may be stopped at any time by pressing the stop button.

This will cause the compressor to unload to minimum and then stop.

The controller will then display the MANUAL OFF mode.

IF 'P-PL' pump pre-lube is selected then the compressor stops with the 'at min' switch open it energises the un-load solenoid until it is made.

MODES CHANGES

Once the compressor is running mode changes are allowed but they will have the following effects:-

i) **Automatic (Remote/Local) to Manual** -The slide will remain at the last selected automatic position. The operator may then select capacity and use the raise/lower buttons as required.

ii) **Manual to Automatic LOCAL** - The controller will use suction pressure regulation to automatically adjust the slide to match demand. If a start/stop refrigeration input is used then if stop is present the compressor will unload to minimum and then stop.

iii) **Manual to Automatic REMOTE** - If this is the only compressor running in REMOTE mode then it will go into suction pressure regulation mode, begin requesting status information and become the master. If another compressor is already master, it will ramp its slide up to 100%.

TWO SPEED MOTOR CONTROL

Relay outputs R8, R9 can be configured as LOWSPEED, HIGHSPEED selections for two-speed motors thus allowing compressors to be run more efficiently at low capacity.

TWO SPEED OPERATION ('2-SP' selected)

In all control modes the LOWSPEED/HIGHSPEED control relays are selected when the pump is started. Whenever R8 (LOWSPEED) relay is energised the slide capacity is always halved (ie maximum capacity is 50%).

If the slide reaches the 'at maximum' limit switch in LOWSPEED mode (normally 50%) then after the stage-up delay the slide is automatically lowered, the motor is stopped, waits for appropriate delays, restarts the pump, selects HIGHSPEED mode and, provided the slide is 'at-minimum', the compressor is restarted in HIGHSPEED mode.

In HIGHSPEED mode, provided the slide has reached 55% capacity, when the capacity goes below the CAPACITY LOW ALARM limit the slide is automatically lowered, the motor stopped and, after the appropriate delays, reverts back to LOWSPEED selection when the pump is re-started.

The motor is subsequently started in LOWSPEED mode provided the slide is 'at-minimum'.

In both HIGH Speed and LOW speed modes a continuous loading pulse is given during the loading delay until the slide has moved from At-Minimum.

Loading/unloading pulses are automatically doubled in width if the suction pressure is more than 0.5 bar from the control setpoint. This improves response after changing speeds.

MANUAL MODE 2-SPEED

In manual mode the compressor stops automatically when 'at maximum' is reached in low speed and below Capacity LOW ALARM limit in high speed.

The compressor must be started again manually in both cases. The motor speed can be forced to be permanently LOWSPEED or HIGHSPEED by selecting 'R8' or 'R9' respectively instead of '2-SP'.

VARIABLE SPEED MOTOR CONTROL

With variable capacity slide.

The motor speed is controlled by analog output AO-2 which provides a signal of 0 to10V dc for 0 to100% motor speed.

The slide capacity is controlled by pulsing the LOAD and UNLOAD relays with a pulse duration equivalent to a 10% capacity increase or decrease.

A theoretical slide position capacity display may be obtained by connecting A01 to the slide input(0-10vdc).

STARTING

With the slide 'at-minimum' (capacity approx 25%) the compressor motor is started at start-stop-speed (SYST noSP,St50,St40,St30,St20,St10,demo).

After the capacity load-delay (approx 3minutes), the capacity solenoid is loaded until at-minimum limit switch is removed. IF SYST 'noSP' is selected then the motor runs at maximum speed and no speed control takes place (standard slide control).

RUNNING

Whilst above start-stop-speed and below 100%-speed, in order to achieve the required suction pressure setpoint the motor speed is varied up and down every five seconds by the speed-increment (SYST Si = approx 2 %).

If the suction pressure goes more than 0.5 bar outside setpoint then the speed increment is automatically doubled.

SLIDE CAPACITY INCREASE

When 100%-speed is reached the load-delay-timer is started. If the suction pressure is outside 0.5bar of setpoint then the load-delay timer is overridden. Each time 100%-speed has been present for greater than the load-delay (3 minutes) then the slide capacity is loaded by a further 10% increment until slide 'at-maximum' is present.

SLIDE CAPACITY DECREASE

When start-stop-speed is reached the load-delay-timer is started and the motor speed is not decreased any further. If the suction pressure is outside 0.5bar of setpoint then the load-delay-timer is overridden.

Each time start-stop-speed (50%) has been present for greater than the load delay (3 minutes) then the slide capacity is unloaded by a further 10% decrement until slide 'at-minimum' is present.

STOPPING

If the compressor is at start-stop-speed with slide 'at-minimum' for longer than the stage-down-time (d) then the motor is switched off and motor speed is run down to zero.

REMOTE MODE- NEXT COMPRESSOR

If the compressor is at 100%-speed with slide 'at-maximum' for longer than the stage-up-time then another compressor in the same pack is allowed to start.

MANUAL MODE OPERATION

In manual mode the compressor speed may be increased/decreased using the raise and lower pushbuttons with mode selection = 'Compressor'.

In manual mode the slide capacity may be increased/decreased using the raise and lower pushbuttons with mode selection = 'Capacity'.

Local or remote operation may then be selected if required

TWO COMPRESSOR-SINGLE MOTOR OPERATION

The facility for two SCC-40 controllers to be connected together in a Master-Slave configuration for applications where two compressors share a single motor will be shortly removed.

It will be replaced at the next documentation issue with 2-Stage compressor control on the SCC50.

Set-up of AUTO VI

for Howden or Dalian Compressors

Auto VI Operation:

Howden and Dalian Refrigeration supply Auto VI Compressors with a stepper motor built into the Volumetric slide.

Guardian SCC50 controllers now provide output signals for direct connection to drive the stepper motor as shown in SCC50 Auto VI Terminal Wiring on page xxx

With the xx VI slide mechanical arrangement there are two modes of operation:

1. **Part Load.** Capacity Slide is not in contact with VI slide.
2. **Full Load.** Capacity Slide is in contact with VI slide.

While the Slide capacity is less than the Initial VI setting the VI slide is set to VI minimum.

Above the Initial VI setting the VI slide is adjusted for the corresponding pressure ratio.(Part Load operation)

When the Capacity slide meets the VI slide the compressor is in Full Load mode and the At Maximum indication is set.

In Full Load mode and the suction pressure is at or above the setpoint, if the VI is decreasing the Capacity slide is moved first as this is able to push the VI slide back. If the VI is increasing the VI stepper is moved first and then the Capacity slide is moved, this ensures that the Capacity slide and VI slide remain in contact during full load mode.

In Full Load mode and the suction pressure is below the setpoint, the VI slide is moved to the calculated position for the pressure ratio and then the At Maximum indication is removed and Part Load operation is resumed.

Procedure

- 1 Check Wiring Connections for stepper motor as drawing on page xxx.
- 2 Switch SCC50 Controller to 'OFF' mode.
- 3 Select **Setup, System, 'noVI'** as SCC50 Manual page 58
- 4 Calibrate Capacity Slide for maximum and minimum as described on SCC50 Manual pages 60.
Note: For Auto VI to work successfully the capacity slide must have been calibrated at the lowest VI setting.
- 5 Select **Setup, System, 'Vi-A'** VI Auto as SCC50 Manual page 58. This allows display and setup of **AUi** settings listed below.
- 6 Setup type for Compressor Model and check Period is 0.5 and Fi=00 (automatic Vi control with recalculation every 30 seconds).
- 7 Enter **test mode** as on as SCC50 Manual page 61 and check pulse outputs are working by :-
 - a) Select ' SsuP' Select Slide up – pulses VI slide to maximum in about 2 minutes.
 - b) Select ' Ssdn' Select Slide down – pulses VI slide to minimum in about 2 minutes.
8. Start compressor. When the slide capacity is above Initial VI setting '**inxx**' the auto VI slide is controlled dependent on the difference between suction and discharge pressure.
The greater the difference the higher the VI ratio. (2.6 to 5.0).
9. The VI ratio currently in force is displayed in the '**Oil**' window by selecting **Equivalent Temperatures, Latest Values**.
10. The value displayed is recalculated and updated every VI Period Px.x minutes.
11. If the capacity slide is at maximum with value > 100% then the slide is automatically unloaded.
12. The compressor may be forced to a fixed VI ratio by selecting Fi (see next page) between 2.6 and 5.0.
To resume Automatic VI, the Fixed VI parameter Fi Must be set to zero Fi=00.
13. On SCC50 Restart Power-up, Compressor Stop or Compressor Trip then the VI slide is pulsed back to zero which takes about 2 minutes.

Auto VI Commissioning Parameters



only displayed if 'VI-A' is selected

	units	Actual setting	Default setting	Min	Max
<p>Compressor Type Specifies the Howden compressor type:</p> <p style="text-align: center;">1 = XRV163/165 4 = XRV204/145</p> <p>NB. Only types 1 and 4 are currently supported. (See attached data sheet for Guardian defaults)</p>		<i>Ct</i>		Ct00	Ct06
<p>Maximum Capacity Travel. This is normally defaulted for the Compressor type selected. However, this may vary depending on Howden configuration, so check with manufacturers data sheets. (See attached data sheet for Guardian defaults)</p>	mm	<i>C</i>		C000	C255
<p>Maximum Slide Stop This is normally defaulted for the Compressor type selected. However, this may vary depending on Howden configuration, so check with manufacturers data sheets. (See attached data sheet for Guardian defaults)</p>	mm	<i>U</i>		U000	U255
<p>Adjustable Parked position. Sets parked position of stepper motor (See attached data sheet for Guardian defaults)</p>	mm	<i>A</i>		A0	A255
<p>Initial VI Setting. Capacity slide percentage at which auto variable VI is applied. (See attached data sheet for Guardian defaults)</p>	%	<i>in</i>		in45	in99
<p>Period Auto VI is applied (Adjustable in 0.1 minute steps, ie 6 seconds) Dependant on application. Recommend starting at 0.5 (30 seconds) and observe system response. If too erratic increase time.</p>	Mins	<i>P</i>		P0.0	P25.5
<p>Fixed VI Setting If a fixed VI condition is required then this may be adjusted to give the required slide stop. When set to 0.0 then Auto variable VI is in action.</p>		<i>Fi</i>		Fi0.0	Fi5.0

Note: For Auto VI to work successfully the capacity slide must have been calibrated at the lowest VI setting.

Guardian Default AVI Data for Howden Compressors.

Compressor Model	Compressor Type	Capacity travel (mm)	Slide Stop (mm)	Parked position (mm)	Initial VI Setting(%)	VI minimum	VI maximum	Parked position (mm)
XRV163/165	Ct 01	C150	U47	A52	In 70	2.6	5.0	52
XRV204/145	Ct 04	C152	U54	A59	In 64	2.6	5.0	59

XXX

TIMER SETPOINTS

Timer delays are displayed in the windows detailed below with selections 'type'= 'TIMERS and 'view'= 'LATEST VALUE'.

All timer delays count down to zero in tenths of a minute :-

Timers are adjusted using 'raise', 'lower', 'next', 'accept' when 'view'= setpoints

Adjustable timers are available for:-

Timer	Window	Range and description	
Stage-Up (u)	SUCTION	0.5 to 12min	Time Compressor at 100% before allowing next compressor to start.
Stage-Down (d)	DISCHARGE	0.5 to 10min	Time compressor at minimum load or time at 50% if in slide balance mode before stopping. Set at 10.0 min = none, NO STOP AT MINIMUM, MANUAL STOP ONLY N.B. To exit none setting = Discharge, Timer, Setpoint, Lower, Accept.
Pre-Lubrication (p)	OIL	0.0 to 5.0min	Oil pump run before compressor starts. At-minimum signal must be present at the end of this timer or a 'S-UP' trip is displayed before the motor is started. On a siphon system this timer is restarted with the motor and inhibits LOW oil differential pressure alarms and trips whilst it is still active.
Pump-off-after Stop (o)	FILTER	0.0 to 5.0min	Oil pump run delay after compressor stops until at-minimum received.
Capacity load delay	CAPACITY%	0.5 to 5.0min	This timer determines the interval between loading/unload pulses when the control is close to (<0.3 bar) the control setpoint. This delay is also used after starting motor before loading pulses are started.
After-Stop	LOAD %	1.0 to 5.0min	the minimum time required after stop before allowing another restart.

The following timers may be adjusted in SETUP SYST

Timer		Range and description	
Starts per hour	SH	0.5 to 12min	The controller restricts the compressor to 20 starts per hour.
Differential alarm delay	dt	0 to 9.9mins	This timer determines the delay before allowing oil differential alarms and trips. It is also used as a delay for oil level or flow safety trips.
Bypass delay	bt	0 to 99 secs	This timer is displayed if 'by-P' is selected and provides a discharge bypass valve pulse of duration bt seconds on output R9. The valve is opened 4 seconds before the motor is started. the bypass is also opened for bt seconds when the compressor is stopped or tripped.
Economiser Back-off delay	Et	0 to 99 mins	This timer determines the delay before allowing the Economiser to switch on again after a load reduction 'back-off'.
Loading pulse Width	LP	0 to 50%	0 to 50% of the 5 second raise-lower period. The value is change using System Setup mode This width is automatically doubled if the suction pressure is more then 0.5 bar above setpoint.
Loading pulse At maximum	LPSt LPPu		Loading pulses stopped, No further Pulses. Loading pulses pulsed, Continued Pulses.
Unloading pulse width	UP	0 to 50%	0 to 50% of the 5 second raise-lower period. The value is changed using system setup mode This width is automatically doubled if the suction pressure is more then 0.5 bar below setpoint.
Raise -Lower period		fixed 5 secs	interval between start of successive raise or lower pulses when 0.3bar outside setpoint.



LOAD% WINDOW; This window displays three timers.



- i) 10.0 - 0.0min Time between starts
- ii) 5.0 - 1.0min Time after stop
- iii) Motor pre-load delay after
When waiting the larger of i) and ii) is displayed.

SETUP

Compressor Settings

Unit Settings:

SUCTION OIL
  Press "next" to sequence through Setup selections

DISCHARGE FILTER Press "raise" or "lower" to change settings
  Press "accept" to accept settings

Unit Model 
 YYYY = SC40 SCC50 conroller PCB with SCC40 Control Panel

Multi-compressor control priority 
 YYYY = runH Priority run on hours
 LEAD Priority always highest
 LAg Priority always lowest
 StbY Only run if another has tripped

Multi-compressors On highway 
 Maximum number of controllers and temperature monitors on COM2 Control Highway
 nn = 1 - 8



Unit type 
 (definition of T5/P5 channel operation)



YYYY = Std Standard SCC-40 operation
 HS-U High side unit dual compressor, 1 motor
 LS-U Low side unit dual compressor, 1 motor
 Vibr P5 is 4-20mA vibration 0-100% with trips
 tcon Control on equivalent temperature
 CHIL Control on water chiller temperature T5
 rt5c Control on glycol chiller temperature T5
 rP5c Control on Remote Pressure P5

System number 
 Not required with MODBUS
 nn = 1 - 80





Compressor number 
 Compressor or temperature Monitor unit address on COM2 Control Highway
 nn = 01 - 08

MODBUS Address 
 nnn = 1 - 255

Temperature Monitor Unit Address 
 COM2 Control Highway address of associated SCC50 temperature Monitor unit.
 n = 1 - 8
 If this unit is the SCC50 temperature monitor unit then this must be the same address
 ie  = 

Control operation	pushbutton		<p>Standard or remote pushbutton operation nnPB= StPb- Standard SCC40 control panel pushbutton operation ISPb Pushbutton operation with additional Intrinsically safe remote pushbuttons as well as SCC40 panel. This requires an SCC50 8X extension unit to be fitted</p>
xx Real time clock		 	<p>Real time hours nn = 0 to 23 Real time mins nn = 0 to 59</p>

System Settings

SUCTION	OIL		
■■■SE	■■■EUP	Press “  next”	to sequence through Setup selections
DISCHARGE	FILTER	Press “  raise” or “  lower”	to change settings
■■■■	SYSE	Press “  accept”	to accept settings
Starts per hour		SHnn	nn = 02 to 19
Loading Valve Polarity		LPoS	= LPoS if loading valve is normally open
		or	
		LnEg	=LnEg if loading valve is normally closed
Unloading Valve Polarity		UPoS	= LPoS if unloading valve is normally open
		or	
		UnEg	=LnEg if unloading valve is normally closed
Loading pulse width		LPnn	nn = 2 to 50 % (% of 6 Second Pulse)
Starting Pulse		SPnn	nn = 0 to 100 % (% of 6 Second Pulse) Initial Starting Pulse, Until at Minimum Removed.
Loading pulses when Slide at Maximum.		LPSt	= Load Pulses stopped @ max
		or	
		LPpU	= Load Pulses continued @ max
Unloading pulse width		UPnn	nn = 2 to 50 % (% of 6 Second Pulse)
Pump Selection		YYYY	
		YYYY=PunP	PunP , Pump Run Compressor
		P-St	P-ST , Pump Start Compressor
		P-PL	P-PL , Pump Pre-Lubrication for Compressor. Pump is run for the duration of the pre-lube timer in the 'Oil' window.
		no-P	no-P , No Pump Compressor
		FiLt	FiLt , Special, Contact Guardian.
Oil Differential alarm trip delay.		dtnn	nn = 0 to 9.9 minutes
If 2Fan,.		bFnn	nn = 0.5 to 9.9 Bar Additional cut-in above setpoint of Fan1 in Discharge, Pressure, Setpoint
Economiser back-off retry time		Etnn	nn = 0 to 99 minutes
Motor start speed if Inverter %		Stnn	nn = 0 to 99 %
Inverter speed increment %		Si,nn	nn = 1 to 20 %

Auto VI Selection.	9999	YYYY=noUi no VI auto do Auto VI
Auxiliary relay R8 and R9 operation mode	9999	YYYY=2-SP two speed motor control (see later section) StbY Standby compressor switch over bY-P Discharge bypass valve operation FANS 2-stage condenser fans control None
Bypass delay if 'bY_P'	6E nn	nn = 0 to 99 seconds
Refrigeration input state for refrigeration ON	9999	YYYY=rPos rnEg
Trip input signal state to trip	9999	YYYY=tPos tnEg
Trip input 8 type.	9999	YYYY=Std. Standard trip function. FLO. Used as second flow fail switch.
Refrigeration gas type	9999	Refrigeration gas type for superheat calculations YYYY=r22 nH3 404A
Filter Differential	9999	Filter Position Relative To Pump YYYY=FStd Filter Standard (Filter After pump) FdiS Filter Discharge (Filter Before Pump)

XXXXX

Analog

SUCTION	OIL	
SE	EUP	Press "next" to sequence through Setup selections
DISCHARGE	FILTER	Press "raise" or "lower" to change settings
	AAAL	Press "accept" to accept settings
Slide voltage range	nn	nn = 0 to 100 C=00 0-10Vdc C=05 is normal setting C=100 for 4-20ma Slide Position Indicator
Slide down at min scale adjustment	Ed	Slide Capacity adjustment when down at minimum The value displayed is the voltage from the potentiometer. The values are saved by pressing accept. Once accept has been pressed the values can also be edited with raise and lower.
Slide up at max scale adjustment	EU	Slide Capacity adjustment up at maximum. The value displayed is the voltage from the potentiometer. The values are saved by pressing accept. Once accept has been pressed the values can also be edited with raise and lower.
Pressure transducer type	Pnn	P=04 4-20mA -1 to 24bar Guardian Transducer P=05 4-20mA -1 to 20bar Danfoss Transducer
Current transformer rating	Ennn	nnn = 10 to 990 Amps
Maximum rated motor load	rnnn	nnn = 10 to 990 Amps
Current source	dC	=0-10vdc Amps transmitter as SCC40
	or	
	Ac	=direct from 0-5A CT secondary to SCC50

PT

SUCTION	OIL	
SE	EUP	Press "next" to sequence through Setup selections
DISCHARGE	FILTER	Press "raise" or "lower" to change settings
	PE	Press "accept" to accept settings
PT1000 or Pt100 selection	A1nn	Hardware switch selection SW1 used to select PT1000 or PT100 probes being used for Temperature inputs AnIP 1. A1oF = normal PT1000 probes in use (sw=0) A1on = PT100 probes (Motor winding temperatures) sw=1) A1nF = not fitted
	etc	
	A6nn	Temperature inputs AnIP 6 A6oF = normal PT1000 probes in use A6on = PT100 probes (Motor winding temperatures) A6nF = not fitted

Test

SUCTION	OIL	
SE	EUPE	Press "next" to sequence through relays
DISCHARGE	FILTER	
	EESE	Press "accept" to toggle relay states
Relay R1	1OFF	1on
Relay R2	2OFF	2on
Relay R3	3OFF	3on
		etc
Relay R9	9OFF	9on
Auto VI slide stepper	SSUP	Move slide stepper out.
Auto VI slide stepper	SSdn	Move slide stepper back.
Alarm relay	AOFF	Aon
LED 1	OFF	ON
		etc
LED 8	OFF	ON
Tripped relay	TOFF	Ton
Analog output calibration	A00	
	A010	
	A005	

Done

SUCTION	OIL	
SE	EUPE	
DISCHARGE	FILTER	
	done	Exit settings change and return to default compressor display press "accept" .

TWO SPEED MOTOR CONTROL SELECTION

Selection

Two-speed motor operation may be selected after entering passcode 15 and then selecting 'type'= SAFETY TRIPS and 'view'= SYSTEM

SUCTION ■■■SE	OIL tUP	“⊙»⊙ _{view} ” = “SYSTEM”	
DISCHARGE ■■■■	FILTER YES	“⊙»⊙ _{type} ” = “SAFETY TRIPS”	
DISCHARGE ■■■■	FILTER none	“⊙ _{accept} ”	
DISCHARGE ■■■■	FILTER SYSE	“⊙»⊙ _{next} ”	
DISCHARGE ■■■■	FILTER UPnn	“⊙ _{accept} ”	DISCHARGE ■■■■
DISCHARGE ■■■■	FILTER 222	“⊙ _{next} ”	FILTER LPnn “⊙ _{next} ”
DISCHARGE ■■■■	FILTER noU	“⊙ _{next} ”	DISCHARGE ■■■■
DISCHARGE ■■■■	FILTER 2-SP	“⊙»⊙ _{raise} ” or “⊙»⊙ _{lower} ”	FILTER noSP “⊙ _{next} ”
		“⊙ _{accept} ” “⊙ _{RESET} ”	

Two speed motor operation has been selected.

Two speed operation may be removed by selecting 'none' instead of '2-SP'

MOTOR TEMPERATURE MONITOR SETUP

Motor Temperature Monitor Setup Selection

The Procedure for adding a SCC50 Motor Temperature Monitor to another SCC50 controller is as follows.

1. Allocate Control Highway Addresses for all SCC50 controllers (total 8 maximum).
Eg for a two compressor LT system both with Motor monitors;

Controller Name	Compr. no	Motor Monitor No.	Max compressors on highway =4
SCC50 LT1 Compressor	001	003	
SCC50 LT2 Compressor	002	004	
SCC50 Motor Monitor LT1	003	003	Cn=Tn = Motor Monitor
SCC50 Motor Monitor LT2	004	004	Cn=Tn = Motor Monitor

2. Wire up COM2 control highway between all compressors and monitor units and fit highway termination links as page 73
3. For each SCC50 Motor Monitor unit, select the appropriate PT1000 /PT100 probe setting on SW-1 bit switches as table on page 22.
4. Plug in SCC40 control panel into the SCC50 Motor Monitor unit and do the following selections for SETUP UNIT and SETUP PT after entering passcode 15 and then selecting 'type'= **SAFETY TRIPS** and 'view'= **SYSTEM**
so for LT1 temperature monitor in example above

“ view” = “SYSTEM”

“ type” = “SAFETY TRIPS”

SUCTION 	OIL 	“”	“ next”	“ next”
DISCHARGE 	FILTER 	“”	“ next”	“ next”
DISCHARGE 	FILTER 	“ raise” or “ lower”	“ next”	“ next”
DISCHARGE 	FILTER 	“”	“ next”	“ next”
DISCHARGE 	FILTER 	“ raise” or “ lower”	“ next”	“ next”
DISCHARGE 	FILTER 	“”	“ next”	“ next”
DISCHARGE 	FILTER 	“ raise” or “ lower”	“ next”	“ next”
DISCHARGE 	FILTER 	“”	“ next”	“ next”
DISCHARGE 	FILTER 	“”	“ next”	“ next”
DISCHARGE 	FILTER 	“”	“ next”	“ next”

DISCHARGE	■■■■	A10F	“⊙»⊙raise” for PT100
		FILTER	
DISCHARGE	■■■■	A10n	“⊙accept” then “⊙next”
		FILTER	
DISCHARGE	■■■■	A20F	“⊙»⊙raise” for PT100
		FILTER	
DISCHARGE	■■■■	A20n	“⊙accept” then “⊙next”
		FILTER	

Repeat for Analog 1 to 6 for appropriate PT1000/PT100 setting on switches.
Any unused probes are selected nF

- Remove control panel from Motor monitor.
- Setup SCC50 compressor controllers for nC, Cn and tn as in example table above .

Motor Temperature Monitor DISPLAY & ALARM LIMITS

When an SCC50 has been is set up with a motor monitor unit , the Motor monitor temperatures and alarm limit settings can be displayed on the SCC40 Display panel as follows;

- Select 'view' on latest values , 'type' on temperature and then Press 'next'
This displays motor Monitor temperature label T1 in CAPACITY window with its temperature value in LOAD for T1. Repeatedly pressing next displays temperatures T2-T6

CAPACITY	LOAD	
■■E1■■	50	“⊙next”
■■E2■■	75	“⊙next”
■■E6■■	-25	“⊙next”

- Alarm and trip limits for each temperature may be displayed using the LOAD window. Select 'view' on **latest values**, 'type' on **temperature** and then Press 'next' until the required temperature is on display in LOAD window as above.
Alarm and trip limits may for the selected temperature may now be viewed in the LOAD window by selecting 'view' to **Low Alarm, High Alarm, Low Trip or High Trip**.
- Alarm and trip limits for each temperature may now be edited using the LOAD window in a similar way to all other temperature displays.
Select 'view' on **latest values**, 'type' on **temperature** and then Press 'next' until the required temperature is on display in CAPACITY and Load windows as above.
Press 'accept' to select temperature
Select Alarm or trip limit to be edited eg High Trip, and press'next until Load window starts to flash.
Use raise and lower to edit new limit setting and then press accept.
- Alarms and trip indications from the motor temperature monitor unit are automatically displayed in the Capacity and Load window with temperature indicator flashing.

CAPACITY	LOAD	LOAD	
■■E1■■	65	H1	“⊙accept”
■■E2■■	75	rIP	“⊙reset”





- Any Motor monitor trips stop the compressor.









TRANSDUCER SETUP & CALIBRATION

TRANSDUCER SETUP

Transducer zero, scale and voltage ranges must be selected prior to calibration and is done as follows:-

Enter set-up as described in earlier section:







“  view” = “SYSTEM”
 “  type” = “SAFETY TRIPS”



SUCTION	OIL
	
DISCHARGE	FILTER
	
DISCHARGE	FILTER
	
DISCHARGE	FILTER
DISCHARGE	FILTER
	

“” “  next”

“”





nn = is slide voltage range 0-10V dc (C -scale) “”
 C 05 = 0-5V dc
 C 41 is a slide giving only 4.1 volts due to line losses instead of 5.0 volts
 C100 is 4-20mA slide input selection





DISCHARGE	FILTER
	
	
DISCHARGE	FILTER
	



nn = P004= 4-20mA transducer -1 to-24bar “”
 nn = P005 = 4-20mA transducer -1 to-20bar
 nnn = is the current transformer rating (T - size) “”
 eg for a CT of 300:5 then nnn = 300

nnn = is the maximum rated motor (R - size) “”
 load in Amps
 eg For a 250Amp compressor nnn = 250

To change any ‘Anal’ (Analog) setting use the following procedure;

“ raise” or “ lower” until correct value is displayed
 “ accept” “ next”

SUCTION	OIL
	
DISCHARGE	FILTER
	

“ accept” “ RESET”

PRESSURE TRANSDUCER SETUP

Xxxx

SUCTION	OIL	
■■■SE	■■■■■■	
DISCHARGE	FILTER	nn = P 04 = 4-20mA transducer
■■■■■	P■■■	

CALIBRATION

4-20mA transducers are calibrated at the factory and should not need to be calibrated at site.

Before attempting Pressure Calibration, please contact Guardian Electronics Ltd.,

Pressure transducers are set for a range of -1 to 24 Barg. (0-25 Bara)

4mA = -1 Barg, 17.44mA = 20 Barg,

Xxxx

Select

'view' = **SYSTEM**,
'type' = **PRESSURE**

With the compressor stopped and slide at 0%.

The CAPACITY% display in the appropriate window is the slide error for 0%.

No	CAPACITY%	LOAD%
■	■■■■■	■■■■■

Using 'next' to select the CAPACITY window, press '**raise**' or '**lower**' to make the displayed value zero and press 'enter'.

The zero offset of the transducer is corrected provided the displayed value is below 15%.

With the slide at full load setting (100%) use 'raise ' and 'lower' to adjust the value to 100% and press 'enter'.

The scale offset of the transducer is corrected.

CAPACITY % SETUP

Slide voltage range must be selected prior to slide calibration. Normal settings for a 1000ohm slide potentiometer using the on-board precision 5vdc connection is:-

SEtuP-AnAL-C_term = C005

Note if the full range of the 1000ohm pot is not used then adjust C005 to C004 or lower until a 0 to 100% scale can be viewed, respective to at minimum and at maximum.

IF a 10vdc slide position transmitter is used then:- SEtuP-AnAL-C_term = C010

IF no slide input is fitted then:- SEtuP-AnAL-C_term = C000

SUCTION	OIL
■■■SE	■■■■EUP
DISCHARGE	FILTER
■■■■■	■■■■0000
	■■
	■■

The Capacity % is then deduced from the state of the slide position microswitches for 0%,50%,100%.

IF a 4-20mA slide transmitter is used then the slide input should setup selection is:-

SEtuP-AnAL-C_term = C100 for 4-20mA

Capacity now has limits for capacity at Min and capacity at Max. The value displayed is the voltage from the potentiometer. 'cd' is when the slide is at min and 'cU' when the slide is at max.

The values are saved by pressing accept. Once accept has been pressed the values can also be edited with raise and lower as follows

When calibrating the slide pot the current value from the slide pot is shown in the oil window and the last stored value is shown in the suction window. Pressing 'raise'/'lower' edits the value in the suction window, pressing 'accept' saves the edited value. If no editing has been done then pressing enter saves the value in the oil window.

MOTOR LOAD % SETUP

IF a 300:5 current transformer is used then SEtuP-AnAL-tnnn = t300

press 'raise' or 'lower' until current transformer size is displayed then press 'accept'.

press 'next'

SUCTION	OIL
■■■SE	■■■■EUP
DISCHARGE	FILTER
■■■■■	■■■■E300

COMMUNICATIONS

The SCC50 has two RS485 communication links Com 1 and Com2.

Com 1 on TB4 is the RS485 Monitor Highway link to a central supervisory system such as Guardian 'Consultant'.

This RS485 link has now been changed to Modbus RTU protocol and no longer supports the former Guardian AGT protocol.

Com2 on TB11 is the RS485 Control Highway link to other Guardian SCC50 Compressors and temperature Monitor Units in the same pack system so that they can arbitrate on inter-compressor master control strategy.

The polling of this RS485 link has now been changed and is no longer compatible with the former SCC40 protocol for inter-compressor communications.

MONITOR HIGHWAY MODBUS COMMUNICATIONS

Remote monitoring, modification and control of the compressor system via COM1 two-wire serial link (RS485) may be provided using the GUARDIAN Consultant. This IBM compatible PC terminal provides displays of latest values, control and alarm settings, timers and compressor status together with daily printouts of pressure and temperature graphs, alarm and trip messages.

Communication facilities are available for interrogation of temperatures, status and modification / display of setpoints, limits and timeclock settings. All communication is via a daisy chain RS485 link which connects all GUARDIAN controllers units in series.

Communication commands and replies are now in **Modbus Protocol** and checked for parity and block length and automatically re-transmit if errors are detected.

Each GUARDIAN controller has a unique unit number address A which is used to select the appropriate unit for interrogation or modification.
GUARDIAN SCC50 controllers are inactive until they are addressed.

MODBUS RTU Communication commands available for a supervisory PLC or PC or Guardian 'Consultant' are:-

- a) Transmit Values which replies with address plus latest pressure, temperature slide and load values, time, trip states, relay states and internal status.
- b) Transmit Setpoints which replies with individual setpoints and limits.
- c) Receive setpoints and limit settings with latest setpoint values.

The Register Allocation and Format types for the SCC50 point data is as follows

Modbus Addressed parameters are read using function code 03, Read Holding registers, and are written to by using function code 16, Pre-set Multiple registers.

MODBUS REGISTER ALLOCATION

REGISTER ADDRESS	DESCRIPTION	RANGE
000	Suction Pressure in Bar gauge	-1.00 to 24.00
001	Discharge Pressure in Bar gauge.	-1.00 to 24.00
002	Oil Pressure after filter in Bar gauge.	-1.00 to 24.00
003	Oil Pressure before filter in Bar gauge.	-1.00 to 24.00
004	Remote Control Pressure, (rP5c selection), in Bar gauge.	-1.00 to 24.00
005	Suction Temperature in degrees C	-90.0 to 150.0
006	Discharge Temperature in degrees C	-90.0 to 150.0
007	Oil Temperature at manifold in degrees C	-90.0 to 150.0
008	Oil Temperature in separator in degrees C	-90.0 to 150.0
009	Remote control Temperature, (rt5c selection), in degrees C	-90.0 to 150.0
00A	Slide Capacity in Percent	0.0 to 100.0
00B	Motor Load in Percent	0.0 to 100.0
00C	Equivalent suction temperature	-90.0 to 150.0
00D	Equivalent discharge temperature	-90.0 to 150.0
00E	Suction superheat	-90.0 to 150.0
00F	Suction to Discharge pressure differential in Bar gauge	-1.00 to 24.00
010	Oil pressure differential in Bar gauge.	-1.00 to 24.00
011	Filter pressure differential in Bar gauge	-1.00 to 24.00
012	Motor current	0.0 to 999.9
013	Motor hours run	0 to 65535

REGISTER ADDRESS	DESCRIPTION	RANGE
014	Suction Pressure alarm status.	See Alarm Format
015	Discharge pressure alarm status.	See Alarm Format
016	Oil Pressure alarm status.	See Alarm Format
017	Filter Pressure alarm status.	See Alarm Format
018	Remote Control Pressure, (rP5c selection), alarm status	See Alarm Format
019	Suction Temperature alarm status	See Alarm Format
01A	Discharge Temperature alarm status	See Alarm Format
01B	Oil Temperature alarm status	See Alarm Format
01C	Filter Temperature alarm status	See Alarm Format
01D	Remote control Temperature, (rt5c selection), alarm status.	See Alarm Format
01E	Slide Capacity alarm status	See Alarm Format
01F	Motor load alarm status	See Alarm Format
020	Equivalent suction temperature alarm status	See Alarm Format
021	Equivalent discharge temperature alarm status	See Alarm Format
022	Suction superheat alarm status	See Alarm Format
023	Suction to Discharge pressure differential alarm status	See Alarm Format
024	Oil pressure differential alarm status	See Alarm Format
025	Filter pressure differential alarm status	See Alarm Format
026	Motor current alarm status	See Alarm Format
027	Motor run hours alarm status	See Alarm Format
028	Relay Output states	See Relay Format
029	Digital Input states	See Input Format
02A	Extension Input states	See Extension Format
02B	Scc50 Mode Selection	See Mode Format

MODBUS FORMAT TYPES

Format Type	Description	Ascii Character	Hex value
Alarm	An ascii character is returned representing the alarm state of the point. Alarm states are: No alarms present High Alarm Low Alarm Trip Transducer Fail	' ' 'H' 'L' 'T' 'F'	020

Format Type	Description	Open State	Closed State
Relay	All 16 bits of the returned value are used to represent the relay states of the controller, they are:- Bit0 = Relay 1, (oil pump) Bit1 = Relay 2, (compressor motor) Bit2 = Relay 3, (Loading valve) Bit3 = Relay 4, (Unloading valve) Bit4 = Relay 5, (Economiser) Bit5 = Relay 6, (Oil cooling) Bit6 = Relay 7, (Oil heater) Bit7 = Relay 8, (not used) Bit8 = Relay 9, (Bypass valve) Bit9 = Relay 10, (Alarm relay) Bit10 = Relay 11, (Tripped relay) Bit11 = Relay 12, (Stepper phase 1) Bit12 = Relay 13, (Stepper phase 2) Bit13 = Relay 14, (Stepper phase 3) Bit14 = Relay 15, (Stepper phase 4) Bit15 = Relay 16, (not used)	0 0 0 0 0 0 0 0 0 0 0 0 0 0 0 0 0	1 1 1 1 1 1 1 1 1 1 1 1 1 1 1 1

Format Type	Description	Open State	Closed State
Input	All 16 bits of the returned value are used to represent the input states of the controller, they are:- Bit0 = Trip 1, (HT safety fault) Bit1 = Trip 2, (LP safety fault) Bit2 = Trip 3, (HP safety fault) Bit3 = Trip 4, (Oil level safety fault) Bit4 = Trip 5, (Oil Flow ok) Bit5 = Trip 6, (Motor circuit breaker) Bit6 = Trip 7, Emergency stop Bit7 = Trip 8, (External Safety fault) Bit8 = Input A, (Max demand unload) Bit9 = Input B, (Key switch) Bit10 = Input C, (At minimum) Bit11 = Input D, (At maximum) Bit12 = Input E, (Oil pump running) Bit13 = Input F, (Motor running) Bit14 = Input G, (Compressor stop) Bit15 = Input H, (not used)	0 0 0 0 0 0 0 0 0 0 0 0 0 0 0 0	1 1 1 1 1 1 1 1 1 1 1 1 1 1 1

Format Type	Description	Open State	Closed State
External Input	The least significant 8 bits of the returned value are used to represent the External input states of the controller, if fitted, they are:- Bit0 = Input 1, (Lock off) Bit1 = Input 2, (Manual mode) Bit2 = Input 3, (Normal operation) Bit3 = Input 4, (External Stop) Bit4 = Input 5, (External Start) Bit5 = Input 6, (External Raise) Bit6 = Input 7, (External Lower) Bit7 = Input 8, (not used)	0 0 0 0 0 0 0 0	1 1 1 1 1 1 1

Format Type	Description	Value
Mode	Reflects the Mode Button Selection on the Scc50, they are: OFF MODE MANUAL COMPRESSOR MANUAL CAPACITY AUTO LOCAL AUTO REMOTE	0 1 2 3 4

MODBUS SYSTEM SETTINGS ADDRESS

5956	Modbus Address	units	Actual setting	Default setting	Min	Max
Motor starts per hour	83		SH04		SH02	SH19
Loading Valve Polarity LpoS = Loading Valve is normally OPEN Lneg = Loading Valve is normally CLOSED	109		LPOS	LPoS	LPoS	Lneg
Unloading Valve Polarity UpoS = Loading Valve is normally OPEN Uneg = Loading Valve is normally CLOSED	103		UPOS	UPoS	UPoS	Uneg
Load pulse width, as a % of 6 seconds Load Pulse Interval Controlled by Capacity Timer Setpoint	14	%	LP08		LP02	LP99
Starting Pulse Initial Loading pulse sent on receipt of compressor run signal, until at minimum signal removed. Output is % of 6 seconds No Initial pulse if set to 0%	75	%	SP00		SP00	SP99
LPSt = pulse stop @ Max, LPPU = cont'd pulse @ Max	77		LPPU		LPSt	LPPU
Unload pulse width, as a % of 6 seconds Load Pulse Interval Controlled by Capacity Timer Setpoint	15	%	UP15		UP02	UP99
Pump Type Selection PunP , Pump Run Compressor P-ST , Pump Start Compressor P-PL , Pump Pre-Lubrication of Compressor no-P , No Pump Compressor FiLt , Special, Contact Microm.	93		no-P		PunP	FiLt
Oil differential trip delay	99	secs	dt30		dt00	dt99
Economiser retry after back off	98	mins	Et05		Et00	Et99
Motor Inverter Minimum Start Speed [Analogue Output (A OP2)] Set To St00 if Not Used	25	%	St00		St00	St99
Auto VI operation mode NoVi/ Vi-A	33		noVi	NoVi	NoVi	Vi-A
Auxiliary relay operation mode 2-SP/Stby/by-P/2Fan/ None/	106		none		2-SP	None
Refrigeration input positive/negative for ON	84		rneg		rPoS	rnEg
Send OFF command on compressor trip (via comms) CnoA = no action, CoFF = Send Off Signal	78		CnoA		CnoA	CoFF
Trip inputs positive tPoS / negative tneg to trip	85		tneg		tPoS	tneg
Trip input 8 Action Selection Std. = normal trip operation Flo. = Flow switch operation	82		Std.	Std.	Std.	Flo.
Gas type (R22, Ammonia NH3 or 404A)	39		404A		r22	404A
Analogue input 5 selection None/Pres4-20/Ptr1000ohm	86		pres	none	none	Ptr
Filter Differential Calculation Fstd , Filter Standard , Diff. Calc. = P4- P3 Filter Located after Pump P4 and before Oil Manifold P3 Fdis , Filter Discharge , Diff. Calc. = P2- P4 Filter Located after Discharge P2 and before Pump P4	III		Fstd	Fstd	Fstd	Fdis

CONTROL HIGHWAY COMMUNICATIONS

When Remote Auto is selected for a compressor, Multi-Compressor pack control for all compressors in the same temperature system is performed as in **iii) REMOTE AUTOMATIC** page 39 and COMPRESSOR CONTROL OPERATION page 42.

This control relies on inter-compressor RS485 communications on COM2 using a Guardian internal protocol.

SCC50 controllers with Motor temperature Monitors also use this highway to request data transmission from the associated Motor temperature monitor unit.

A maximum of eight controllers and monitors may be fitted to a control highway system.

The maximum number of compressors on the COM2 Control highway, the control highway address of the unit and the associated temperature monitor unit address must be setup as detailed in Unit Settings: page 56







A two-wire screened communication cable must be connected to all SCC50 controllers and temperature monitors on the same temperature control system as follows.





Different Termination resistor links must be selected for the first, the last and all middle controllers as indicated.

Control Highway Communication Wiring
Internal Communications between Compressors

Main Set-up/ Commissioning Parameters

Enter Passcode

“  view” = “SETPOINT”					
“  next” “  next”					
SUCTION	OIL				
PASS	code				
DISCHARGE	FILTER	“  »  raise”	DISCHARGE	FILTER	“  accept”
■■■■	■■■■		■■■■	■■■■	

“  »  view” = “SYSTEM”			
“  »  type” = “SAFETY TRIPS”			
SUCTION	OIL		
■■SE	EOP		
DISCHARGE	FILTER		
■■■■	■■■■	“  accept”	

Unit

	units	Actual setting	Default setting	Min	Max
Model type		1-St		1-St	1-St
Remote control mode runH/LEAd/LAg/StbY				runH	StbY
Number of compressors in same suction group(inter-compressor comms on RS485)		nC		1	8
Starting Window(un-tested function should be left at zero 0 = Not used, 1= Even minutes, 3=odd minutes)		Su0		0	3
Control type Std/----/----/Uibr/tcon/CHIL/----/rt5c/rP5c/diSc				Std.	diSc
System Number - NOT now required with MODBUS		Sn0		Sn0	Sn80
Compressor number this compressor		Cn		Cn01	Cn06
MODBUS Monitor Address		A		A 01	A255
Control pushbutton operation StPb- Standard SCC40 control panel pushbutton operation o iSPb Pushbutton operation with additional Intrinsically safe remote pushbuttons as well as SCC40 panel.				StPb	iSPb

Real Time Clock

Real Time Clock	Hrs	rh		rh00	rh24
-----------------	-----	----	--	------	------

Real Time Clock	mins	<i>rt</i>		rt00	rt59
-----------------	------	-----------	--	------	------

Main Set-up/ Commissioning Parameters Cont'd

011P	units	Actual setting	Default setting	Min	Max
Pump Type Selection PunP , Pump Run Compressor (Oil Differential, Oil P3 to Discharge P2) P-ST , Pump Start Compressor (Oil Differential, Oil P3 to Suction P1) P-PL , Pump Pre-Lubrication of Compressor (Oil Differential, Oil P3 to Suction P1) no-P , No Pump Compressor (Oil Differential, Oil P3 to Suction P1) FiLt , Special, Contact Guardian.				PunP	FiLt
Number of Oil pumps.		nP01		nP01	nP02
Oil differential trip delay	secs	dt		dt00	dt99
Maximum time to Unload to minimum before starting. To prevent start with too much oil in compressor.	secs	Ut0.5		ut0.0	ut9.9
Speed Increment when vsd is used with oil pump.	%	Si00		Si00	Si99

5456	units	Actual setting	Default setting	Min	Max
Control deadband		d0.02		d0.00	d0.30
Motor starts per hour		SH		SH02	SH99
Loading Valve Polarity LpoS = Loading Valve is normally OPEN Lneg = Loading Valve is normally CLOSED		L	LPoS	LPoS	Lneg
Unloading Valve Polarity UpoS = Loading Valve is normally OPEN Uneg = Loading Valve is normally CLOSED		U	UPoS	UPoS	Uneg
Load pulse width, as a % of 6 seconds Load Pulse Interval Controlled by Capacity Timer Setpoint	%	LP		LP02	LP99
Starting Pulse Initial Loading pulse sent on receipt of compressor run signal, until at minimum signal removed. Output is % of 6 seconds No Initial pulse if set to 0%	%	SP		SP00	SP99
LPSt = pulse stop @ Max, LPPU = cont'd pulse @ Max		LP		LPSt	LPPU
Unload pulse width, as a % of 6 seconds Load Pulse Interval Controlled by Capacity Timer Setpoint	%	UP		UP02	UP99
Economiser retry after back off	mins	Et		Et00	Et99
Motor Inverter Minimum Start Speed [Analogue Output (A OP2)] Set To St00 if Not Used	%	St		St00	St99
(If Speed Inverter) , Speed Increment	%	Si		Si01	Si20
Auto Vi operation mode. Vi-A is untested. Vi-F is for a fixed Vi operation and uses relay Relay 8 to load the Vi Slide and Relay 9 to unload it. NoVi/ Vi-A/Vi-F			NoVi	NoVi	Vi-A
Auxiliary relay R8/R9 operation mode 2-SP/Stby/by-P/2Fan/ None/				2-SP	None
(IF bY- P) Bypass delay time, On 4secs before comp starts & On at compressor STOP. (output=R9, RL9)	secs	bt		bt05	bt99
Refrigeration input positive/negative for ON		r		rPoS	rnEg
Force unload period during motor overload condition. Unload output is closed for this period.	secs	Fu05		Fu00	Fu20
Overload condition retry period. Sets the delay before loading can recommence after an overload condition.	mins	rP0.5		rP0.0	rP9.9

Trip inputs positive tPoS / negative tneg to trip		t		tPoS	tneg
Trip input 8 Action Selection Std. = normal trip operation Flo. = Flow switch operation			Std.	Std.	Flo.
Gas type (R22, Ammonia NH3 or R507)				r22	R507
Analogue input 5 selection None/Pres4-20/Ptr1000ohm			none	none	Ptr
Filter Differential Calculation Fstd, Filter Standard , Diff. Calc. = P4- P3 Filter Located after Pump P4 and before Oil Manifold P3 Fdis, Filter Discharge , Diff. Calc. = P2- P4 Filter Located after Discharge P2 and before Pump P4		F	Fstd	Fstd	Fdis
Capacity Slide limit switches fitted/Not fitted 0=Fitted 1=Not fitted.		Li00		Li00	Li01
Fixed Vi slide period. Time required to move Vi Slide from minimum to required position and from required position back to minimum.	mins	iP0.5		Ip0.0	Ip9.9

Hrun

Hours run adjustment		H		H -99	H127
----------------------	--	----------	--	--------------	-------------

ANAL Analogue Set-up

Slide scale (0 = none, 5 = standard) C100 is 4-20mA slide input selection		C		C 00	C100
Capacity Slide potentiometer voltage when at min		cd		Cd0.0	Cd10.0.
Capacity Slide potentiometer voltage when at max		cU		CU0.0	CU10.0.
Pressure transducer type P=04 4-20mA Guardian -1 to 24bar Transducer P=05 4-20mA Danfoss -1 to 20bar Transducer P=06 4-20mA Suction is -1 to 24bar Transducer, all others are -1 to 34bar Transducers.		P		P 00	P255
Load transformer current rating ratio (txxx:5)	Amp	t		t000	t990
Motor maximum current rating (rxxx)	Amp	r		t000	t990
Current measurement source dC 0-10vdc from Current transmitter using An IP14 on TB7/1,2 AC direct 0-5A input from Current Transformer on An IP15 TB7A		dC		dC	AC

PT PT1000 or PT 100 Switch Selection

Hardware switch selection used to select PT1000 or PT100 probes being used for Temperature inputs AnIP 1. A1oF = normal PT1000 probes in use switch=0 A1on = PT100 probes (Motor winding temperatures) switch=1 A1nF = not fitted		A1	A1oF	A1oF	A1nF
AnIP 2 selection		A2	A2oF	A2oF	A2nF
AnIP 3 selection		A3	A3oF	A3oF	A3nF
AnIP 4selection		A4	A4oF	A4oF	A4nF
AnIP 5 selection		A5	A5oF	A5oF	A5nF
AnIP 6 selection		A6	A6oF	A6oF	A6nF

Setup / Commissioning Parameters

PRESSURES								
Display Window	'type' selection	'view' selection	Settings	unit	Actual Setting	Default Setting	Min	Max
SUCTION	PRESSURE	SETPOINT	Suction Pressure setpoint (Fixed Control Diff +/- 0.1bar) NB When in 'rP5c' Display is a duplicate of Filter/Equivalent/Setpoint.	bar			-0.6b	24.0b
DISCHARGE	PRESSURE	SETPOINT	ONLY If 'FANS' selected, condenser fan1 on @ setpoint, off @ 0.5b below setpoint	bar			5.0	20.0
CAPACITY	PRESSURE	SETPOINT	Economiser on at slide greater than	%			0	100
LOAD	PRESSURE	SETPOINT	% load current above which capacity unload pulses are started	%			50	99
SUCTION	PRESSURE	LOW ALARM	Stops compressor on low suction pressure (Automatic Restart)	bar			-1.0b	5.0b
CAPACITY	PRESSURE	LOW ALARM	Load Sharing Compressors Minimum slide % at which a load-sharing compressor is allowed before it auto-stops after stage-down time. Load Sharing OFF When set to 0%	%			0	80
SUCTION	PRESSURE	HIGH ALARM	hi-alarm suction pressure	bar			0.0b	20.0b
DISCHARGE	PRESSURE	HIGH ALARM	hi-alarm disc pressure (unload)	bar			0.0b	23.0b
CAPACITY	PRESSURE	HIGH ALARM	Maximum slide capacity above which the compressor inhibits loading pulses.	%			50	110
LOAD	PRESSURE	HIGH ALARM	% load current above which alarm generated	%			75	100
SUCTION	PRESSURE	LOW TRIP	Low-trip suction pressure (Comp Stop Manual Reset Required.)	bar			-1.0b	5.0b
CAPACITY	PRESSURE	LOW TRIP	Compressor Auto-stops when slide below Capacity, Pressure, Low-trip % , for stage down time period. No Action When Set to Zero 0% Restart after Starts/Hour timer SH	%			0	100
LOAD	PRESSURE	LOW TRIP	low-trip motor current	%			-11	50
SUCTION	PRESSURE	HIGH TRIP	high-trip suction pressure	bar			0.0b	20.0b
DISCHARGE	PRESSURE	HIGH TRIP	high-trip discharge pressure	bar			0.0b	23.0b

TEMPERATURES								
Display Window	'type' selection	'view' selection	Settings	unit	Actual Setting	Default Setting	Min	Max
DISCHARGE	TEMP	SETPOINT	Liquid injection / Oil cooler output, RL6, On at setpoint Discharge temp T2, Off at 5C below setpoint.	°C			40c	85c
FILTER	TEMP	SETPOINT	Switch off oil heater if greater than T4	°C			0c	50c
FILTER	TEMP	LOW ALARM	Inhibit start/heater-on if less than T4	°C			-6c	35c
SUCTION	TEMP	HIGH ALARM	hi-alarm suction temperature	°C			-40c	90c
DISCHARGE	TEMP	HIGH ALARM	hi-alarm discharge temperature	°C			40c	127c
OIL	TEMP	HIGH ALARM	hi-alarm Oil temperature (T3 Injection Manifold)	°C			40c	127c
SUCTION	TEMP	HIGH TRIP	hi-trip suction temperature	°C			-46c	100c
DISCHARGE	TEMP	HIGH TRIP	hi-trip discharge temperature	°C			40c	127c
OIL	TEMP	HIGH TRIP	hi-trip oil temperature (T3 injection manifold)	°C			40c	127c

EQUIVALENTS								
Display Window	'type' selection	'view' selection	Settings	unit	Actual Setting	Default Setting	Min	Max
SUCTION	EQUIV	SETPOINT	IF 'tcon', Suction equivalent temp setpoint	°C			-50	50
FILTER	EQUIV	SETPOINT	IF 'CHIL', Water chiller temp setpoint	°C			-1.0	24.0

rt5c Remote Temperature 5 Control								
FILTER	EQUIV	SETPOINT	IF 'rt5c', Glycol Temperature Control Setpoint	°C			-37	30
FILTER	EQUIV	LOW ALARM	IF 'rt5c' Glycol temperature Low Alarm	°C			-47	50
FILTER	EQUIV	HIGH ALARM	IF 'rt5c' Glycol temperature High Alarm	°C			-28	127
FILTER	EQUIV	LOW TRIP	IF 'rt5c' Glycol temperature Low Trip	°C			-47	50
For rt5c set board links to LK01 CLOSED, LK02 OPEN								

rP5c Remote Pressure 5 Control								
FILTER	EQUIV	SETPOINT	IF 'rP5c', Remote Pressure Control Setpoint NB When in rP5c Display Setting is duplicated at Suction/Pressure/Setpoint	bar			-1.0	24.0
FILTER	EQUIV	LOW ALARM	IF 'rP5c' Remote Pressure Low Alarm	bar			-1.0	20.0
FILTER	EQUIV	HIGH ALARM	IF 'rP5c' Remote Pressure High Alarm	bar			-1.0	24.0
FILTER	EQUIV	LOW TRIP	IF 'rP5c' Remote Pressure Low Trip	bar			-1.0	20.0
FILTER	EQUIV	HIGH TRIP	IF 'rP5c' Remote Pressure High Trip	bar			-1.0	24.0
For rP5c set board links to LK01 OPEN, LK02 CLOSED Note rP5c Alarms and Trips have a delay of 60 seconds								

DIFFERENTIALS								
Display Window	'type' selection	'view' selection	Settings	unit	Actual Setting	Default Setting	Min	Max
OIL	DIFF	SETPOINT	If ' P-St ' ERROR MESSAGE , Actually Repeat of OIL DIFF LOW TRIP, DO NOT ADJUST	bar			-1.0b	5.0b
DISCHARGE	DIFF	SETPOINT	If ' P-St ', Differential discharge to suction above which pump is stopped if only required during start-up.	bar			5.0	20.0
SUCTION	DIFF	LOW ALARM	low-alarm suction superheat (Suction actual temp T1 – suction equivalent temp P1)	°C			-46c	20c
DISCHARGE	DIFF	LOW ALARM	If ' By-P ', lo-alarm differential, Discharge P2 to Suction P1, After FIXED 2min timer	bar			0.0	10.0
OIL	DIFF	LOW ALARM	Low-alarm oil pressure differential (After dt Oil diff trip delay) If ' No-Pump ' or P-PL oil P3 – Suction P1 diff If PUMP oil P3 – Discharge P2 diff	bar			-1.0b	5.0b
SUCTION	DIFF	HIGH ALARM	high-alarm suction superheat (Suction actual temp T1 – suction equivalent temp P1)	°C			05c	100c
FILTER	DIFF	HIGH ALARM	High Alarm Filter Differential IF 'PUMP' & 'FStd' Selected (Filter Inlet Press4 – Manifold oil pressure Press3) IF 'PUMP' & 'Fdis' Selected (Filter inlet Press2 Discharge—Oil Pump inlet Press4) IF 'No-P', 'FStd', 'SCC30/35' (Filter inlet Press P2—Oil Press P3) After FIXED 2min timer	bar			0	20.0
SUCTION	DIFF	LOW TRIP	Low-trip suction superheat (Suction actual temp T1- Suction equivalent temp P1) After FIXED 10min timer.	°C			-46c	30c
DISCHARGE	DIFF	LOW TRIP	If ' By-P ', lo-trip differential, Discharge P2 to Suction P1, After FIXED 2min timer	bar			0.0b	10.0b
OIL	DIFF	LOW TRIP	Low-Trip oil pressure differential (After ' dt ' oil trip delay) No-Pump or P-ST = oil P3 to Suction P1 diff PUMP = oil P3 to Discharge P2 diff 1 Compressor STARTS when at MIN and differential satisfied or TRIPS (on pre lube time-out, OIL TIMER SETPOINT) 2 ' dt ' time commences only when OIL DIFF LOW TRIP is satisfied 3 IF Slide not returned to MIN Within dt time then Oil Drain Delay Commences for ' SH ' Starts per Hour Timeout.	bar			-1.0b	5.0b

DIFFERENTIALS Cont'd								
Display Window	'type' selection	'view' selection	Settings	unit	Actual Setting	Default Setting	Min	Max
SUCTION	DIFF	HIGH TRIP	high-trip suction superheat (Suction actual temp T1--Suction equivalent temp P1) After FIXED 10min timer.	°C			-40c	100c
FILTER	DIFF	HIGH TRIP	High Trip Filter Differential IF PUMP & FStd Selected (Filter Inlet Press P4 – Manifold oil pressure Press P3) IF PUMP & Fdis Selected (Filter inlet Press P2 Discharge—Oil Pump inlet Press P4) If No-P,FStd,SCC30/35 (Filter inlet Press P4—Oil Press P3) After FIXED 2min timer	bar			0.0	20.0

Display Window	'type' selection	'view' selection	Settings	unit	Actual Setting	Default Setting	Min	Max
TIMERS								
SUCTION	TIMERS	SETPOINT	stage up delay (time @ 100% before allowing next compressor to start)	(u)	mins		0.1u	12.5u
DISCHARGE	TIMERS	SETPOINT	stage down delay (time @ minimum load or 50% if in slide balance mode before stopping) Set at 10.0 = none, NO STOP AT MINIMUM, MANUAL STOP ONLY. N.B. To exit none setting = Discharge, Timer, Setpoint, Lower, Accept.	(d)	mins		0.1d	10.0d none
OIL	TIMERS	SETPOINT	pump pre-lube delay (pump run time before compressor starts)	(p)	mins		0.2P	5.0P
FILTER	TIMERS	SETPOINT	pump delay after compressor stops until at-minimum received	(o)	mins		0.0o	5.0o
CAPACITY	TIMERS	SETPOINT	slide load delay (interval between pulses when control within 0.3b)		mins		0.1	5.0
LOAD	TIMERS	SETPOINT	minimum delay after stop before allowing restart		mins		0.3	12.5

CALIBRATION

4-20mA transducers are calibrated at the factory and should not need to be calibrated at site.

Before attempting Pressure Calibration, please contact Guardian Electronics Ltd.,

Pressure transducers are set for a range of –1 to 24 Barg. (0-25 Bara)

4mA = -1 Barg, 17.44mA = 20 Barg,

CAUTION, Do not press the accept button if during calibration the display reads –1.3Barg, as this is an out of range setting and will result in a permanent loss of calibration.

Settings display and change facilities.

'view' LATEST VALUE						
'type'	SUCTION	DISCHARGE	OIL	FILTER	CAPACITY%	LOAD%
PRESSURE	A1 bar	A2 bar	A3 bar	A4 bar	A9	A10
TEMPERATURE	A5 °C	A6 °C	A7 °C	A8 °C	A9	A10
EQUIV TEMP	A17 °C	A18 °C		A11 °C	A9	A10
DIFFERENTIAL	A17 - A5°C	A2 - A1 b	A3 - A2 b	A4 - A3 b	A9	A10
HOURS RUN	/1000		000Hrs		A9	A10
TIMERS (mins)	stage-up	stage-down	pre-lub	pump-off	preload	after-stop
SAFETY TRIPS	L.P.	H.P.	Leu.	Flo.	Econ.on	Stop-load

'view' SETPOINTS						
'type'	SUCTION	DISCHARGE	OIL	FILTER	CAPACITY%	LOAD%
PRESSURE	Control	Fans				
TEMPERATURE		LIQ.INJ.	on			
EQUIV TEMP	Control			Chiller		
DIFFERENTIAL		stop-pump				
HOURS RUN						
TIMERS (mins)	stage-up	stage-down	pre-lub	pump-off	pre-load	after-stop
SAFETY TRIPS						

'view' LOW ALARM						
'type'	SUCTION	DISCHARGE	OIL	FILTER	CAPACITY%	LOAD%
PRESSURE	stop		yes			
TEMPERATURE			pump-inh		min-load	
EQUIV TEMP				yes		
DIFFERENTIAL	yes		yes	yes		
HOURS RUN						
TIMERS (mins)						
SAFETY TRIPS						

'view' HIGH ALARM						
'type'	SUCTION	DISCHARGE	OIL	FILTER	CAPACITY%	LOAD%
PRESSURE	yes	yes	yes		stop-load	start-unload
TEMPERATURE	yes	mot.inh	yes			
EQUIV TEMP				yes		
DIFFERENTIAL	yes			yes		
HOURS RUN						
TIMERS (mins)						
SAFETY TRIPS						

Settings display and change facilities cont'd.

'view' LOW TRIP						
'type'	SUCTION	DISCHARGE	OIL	FILTER	CAPACITY%	LOAD%
PRESSURE	yes					
TEMPERATURE						
EQUIV TEMP				yes		
DIFFERENTIAL	yes		yes	yes		
HOURS RUN						
TIMERS (mins)						
SAFETY TRIPS						

'view' HIGH TRIP						
'type'	SUCTION	DISCHARGE	OIL	FILTER	CAPACITY%	LOAD%
PRESSURE	yes	yes				
TEMPERATURE		yes	yes			
EQUIV TEMP				yes		
DIFFERENTIAL	yes			yes		
HOURS RUN						
TIMERS (mins)						
SAFETY TRIPS						

'view' SYSTEM						
'type'	SUCTION	DISCHARGE	OIL	FILTER	CAPACITY%	LOAD%
PRESSURE	cal - A1	cal - A2	cal - A3	cal - A4	cal - A9	cal - A10
TEMPERATURE						
EQUIV TEMP						
DIFFERENTIAL						
HOURS RUN						
TIMERS (mins)						
SAFETY TRIPS	SYSTEM STATUS & SETUP MODE					

SCC-50 Enclosure wiring: for trips negative

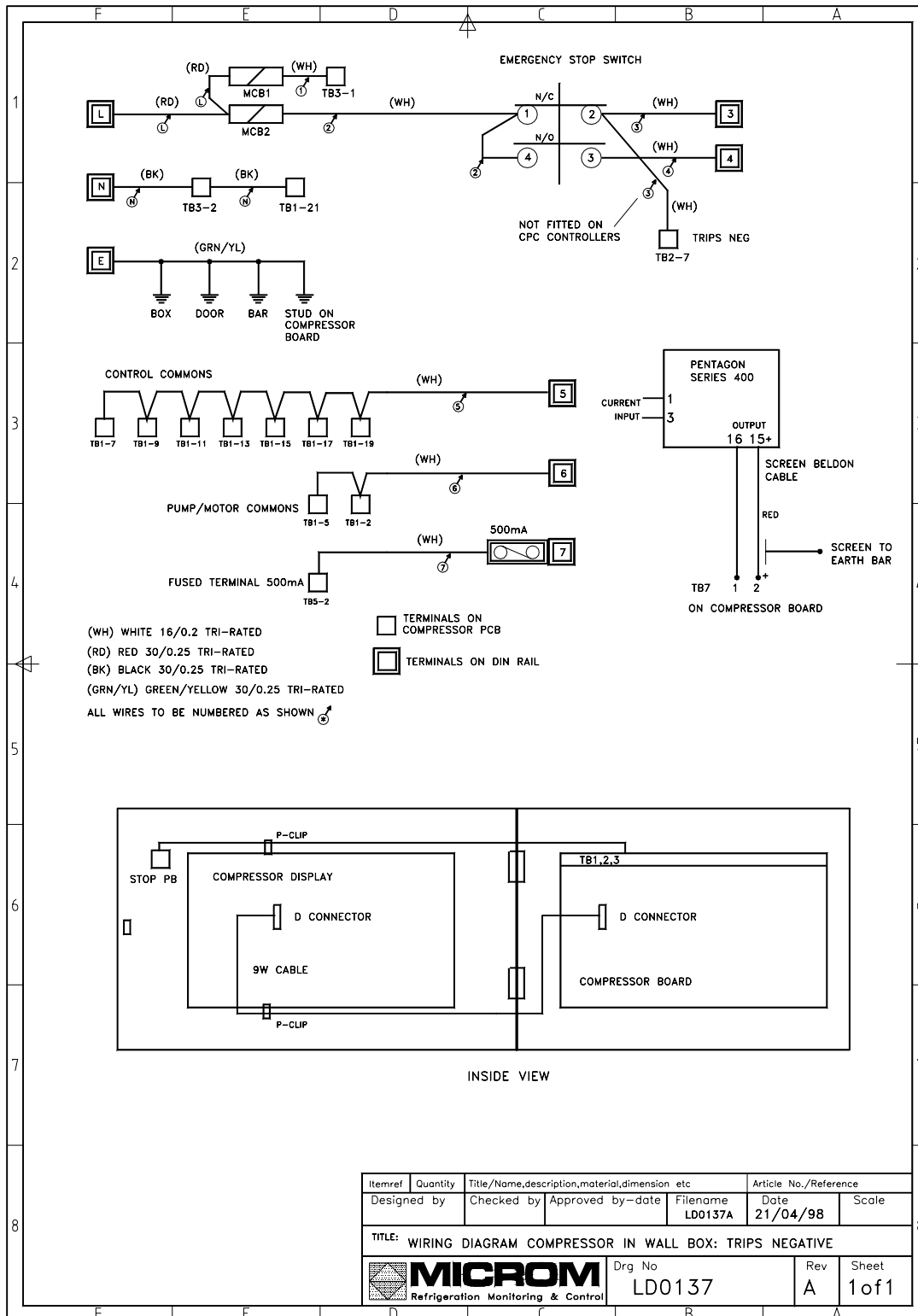

Standard Wallbox Internal wiring

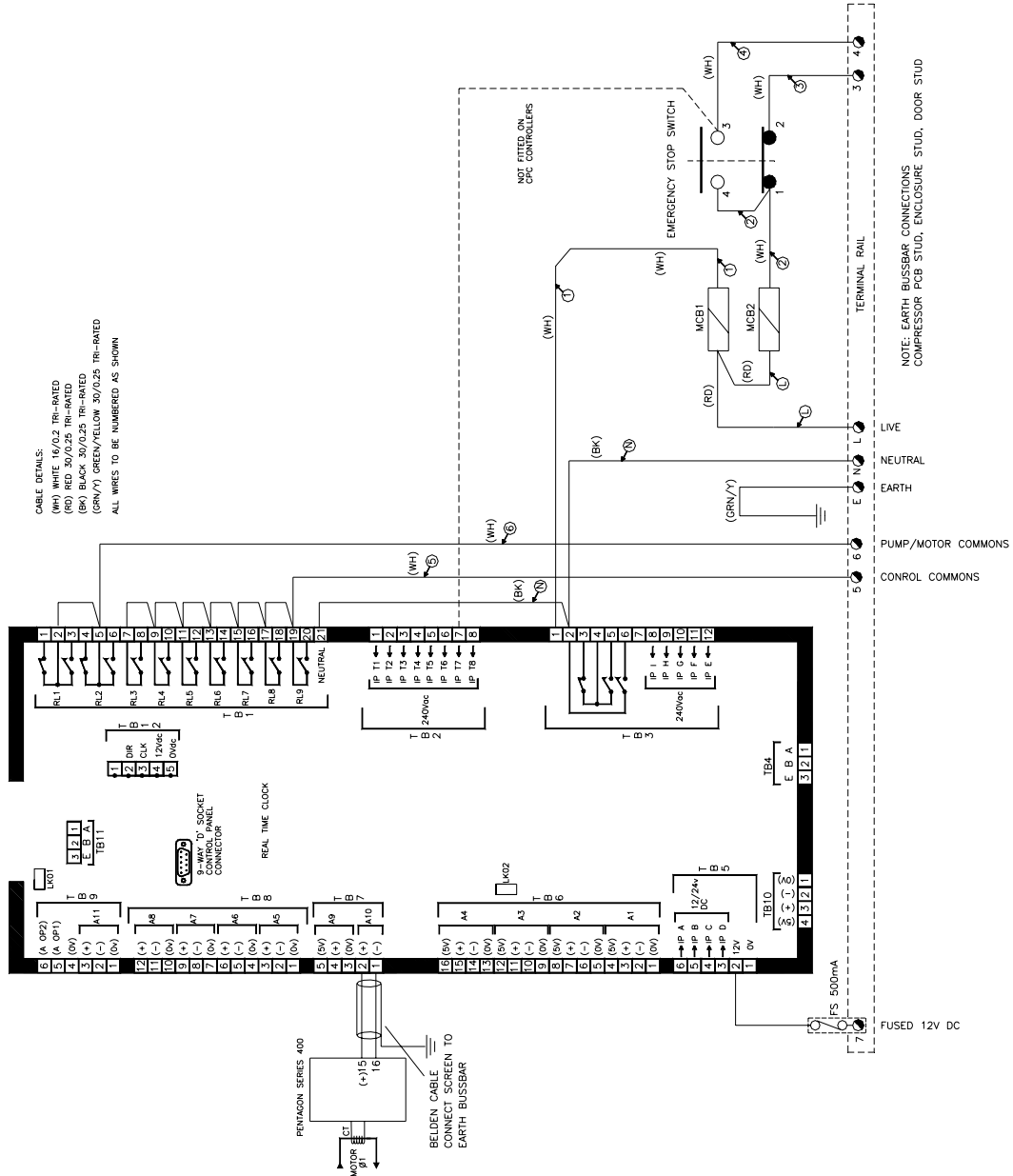

Standard SCC 40 Drawing

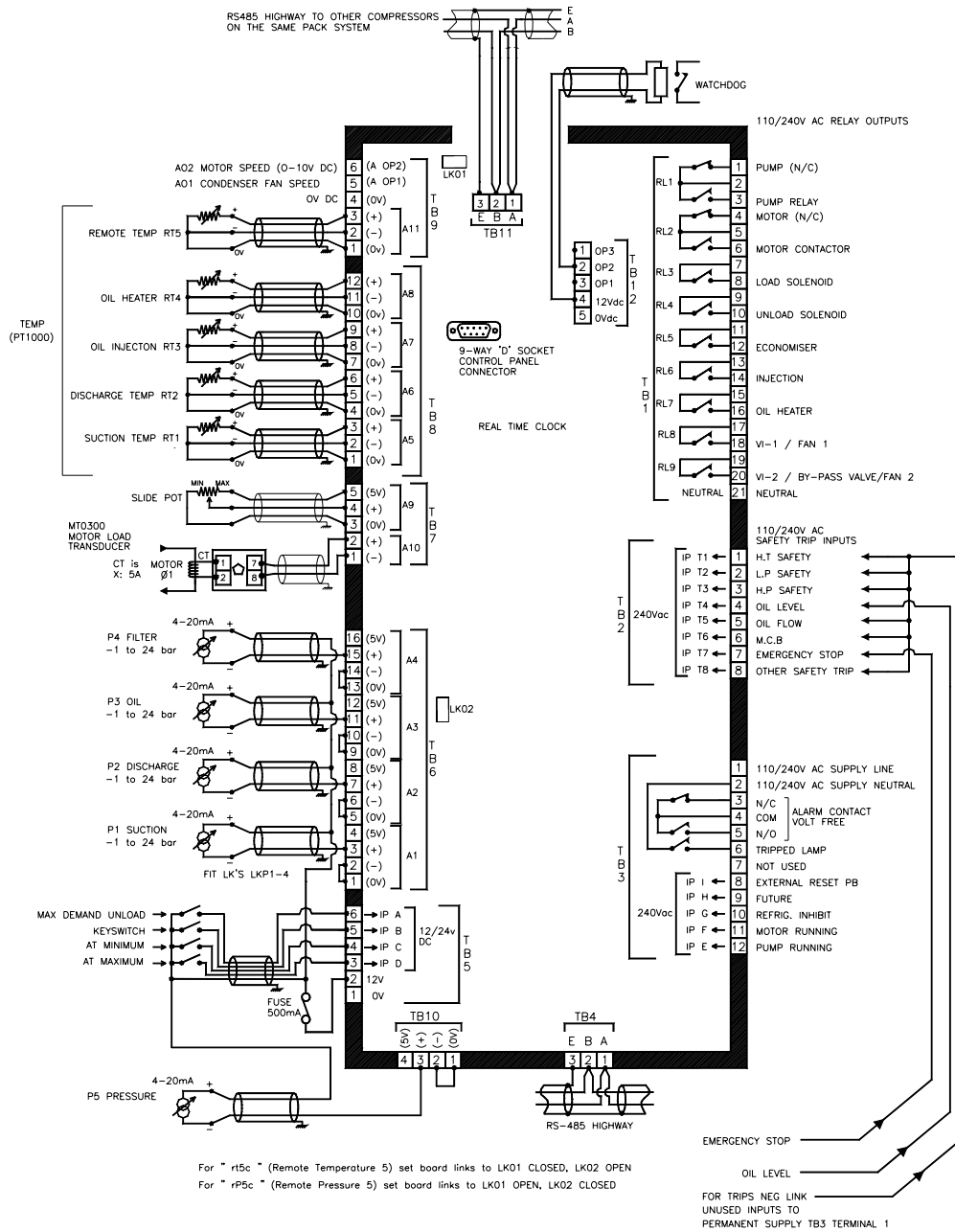

FITTING NEW EPROM

**NOTE POSITION BEFORE REMOVAL.
ACTUAL LOCATION MAY BE REVERSED**

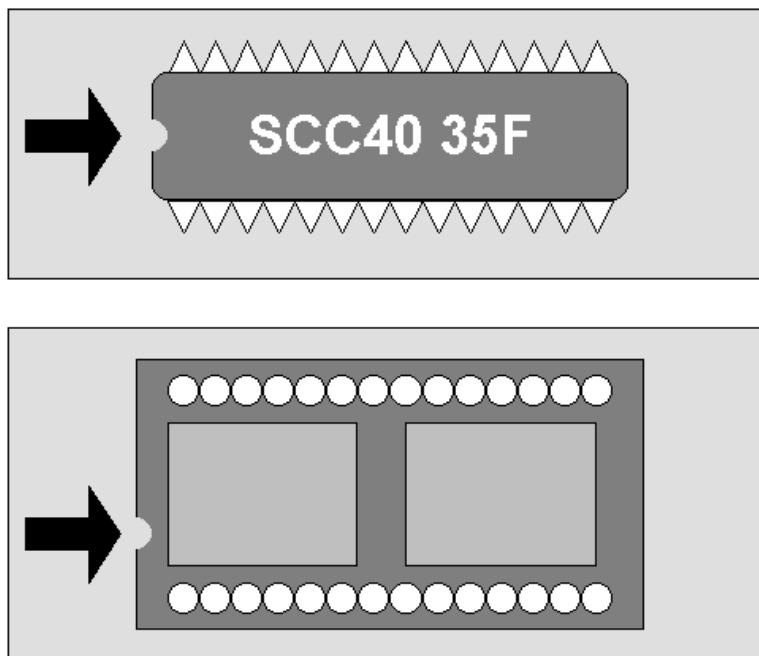

**CORRECT POSITIONING OF EPROM
ALIGN INDICATED INDENTS**

Index

- 8-X Inputs, 27
- Accept, 35
- ALARM ACCEPT AND RESET, 36
- Analog, 62
- Auto VI Commissioning Parameters, 54
- Auto VI Operation:, 52
- Auto VI Stepper Motor wiring, 20
- AVAILABLE UNIT MODELS, 14
- BUTTON OPERATION SHORTHAND, 6
- CAPACITY % SETUP, 69
- COMMUNICATIONS, 71
- COMPRESSOR CONTROL OPERATION, 43
- Compressor Settings, 58
- CONFIGURE UNIT MODEL, SYSTEM No & ADDRESS, 7
- CONTROL, 43
- Control Highway Communication Wiring, 76
- CONTROL MODES, 40
- CONTROL PUSHBUTTON OPERATION, 33
- Control status displays., 26
- DISPLAY INDICATIONS, 24
- DISPLAY PUSHBUTTON OPERATION, 30
- Displays, 10
- Done, 63
- Enter Passcode, 7
- FITTING NEW EPROM, 90
- Functions, 9**
- GENERAL, 40
- GENERAL SPECIFICATION, 12
- GETTING STARTED, 5
- HARDWARE CHECKS, 6
- Inputs, 27
- LED LAMPS., 24
- LOCAL AUTOMATIC, 40
- Lower, 34, 35
- Main Set-up/ Commissioning Parameters, 77
- MANUAL, 40
- mode, 33
- Mode-AUTOMATIC, 33
- Mode-MANUAL, 33
- MODES CHANGES, 47, 48, 51
- MOTOR LOAD % SETUP, 69
- next, 35
- Old Model SCC-40 Termination Wiring, 19
- GUARDIAN SCC-50 Operator Manual
- OPERATION, 23
- OVERVIEW, 9
- POWER UP, 43
- PRESSURE TRANSDUCER SETUP, 68
- PT, 62
- Pushbuttons., 10
- raise, 35
- Raise, 34
- RCC40 PANEL LAYOUT, 23
- Relay output status., 26
- REMOTE AUTOMATIC, 40
- RESET, 33
- RS485 Communications, 8
- RUNNING, 43, 44
- SAFETY TRIP INDICATIONS, 29
- SCC50 8-X Extension - Terminal Connections for Hazardous Area Panel, 21
- SCC-50 Motor Monitor Temperature Wiring, 22
- SCC-50 Enclosure wiring: for trips negative, 86
- SCC-50 Enclosure wiring: for trips positive., 87
- SCC-50 Input/Output Signals, 15, 22
- SCC-50 Termination Wiring -, 18
- Select System No and Address, 8
- Select Unit Model, 7
- SETPOINTS, 38
- SETTINGS CHANGE PUSHBUTTON OPERATION, 35
- SETUP, 58
- Standard SCC 40 Drawing, 89
- Standard Wallbox Internal wiring, 88
- start, 34
- stop, 34
- STOPPING, 45, 47
- System Settings, 60
- SYSTEM STATUS DISPLAYS, 25
- Test, 63
- TIMER SETPOINTS, 56
- TRANSDUCER SETUP & CALIBRATION, 67
- TRANSDUCER SETUP, 67
- Trip inputs., 28
- type, 30
- UNIT MODELS, 9
- Unit Settings:, 58
- view, 30

